



IL DESIGN CHE ILLUMINA  
DESIGN THAT ILLUMINATES

NATEVO



Nel 2013 nasce Natevo: la prima azienda Italiana a progettare, realizzare e commercializzare mobili con luce a LED integrata in grado di illuminare autonomamente l'ambiente senza la necessità di altri corpi illuminanti.

Natevo si propone come progetto ad alto tasso etico, una missione di impegno sociale volta a ridurre i costi energetici ed economici sia nella costruzione di nuovi edifici che nelle ristrutturazioni e offre all'interior designer un modo nuovo di concepire la luce, non solo come elemento necessario ma come fonte di armonia, calore ed emozione.

Questo catalogo illustra l'intera gamma dei prodotti Natevo descritti nel dettaglio delle loro proprietà illuminotecniche e inseriti in progetti abitativi che mettono in risalto la loro duplice valenza: decorativa e funzionale.

Sono progettati da designer portatori di linguaggi diversi e rivelano la continuità di una ricerca che unisce qualità, esperienza e passione per un nuovo e più consapevole stile di vita.

2013 saw the birth of Natevo: the first Italian company to design, manufacture and market furniture with integrated LED lighting capable of independently illuminating the environment without the need for other lighting fixtures.

Natevo presents itself as a highly ethical project, a mission of social commitment aimed at reducing energy and economic costs both in the construction of new buildings and in renovations. It offers interior designers a new way of conceiving light, not only as a necessary element but as a source of harmony, warmth and emotion.

This catalogue illustrates the entire range of Natevo products described in detail of their lighting properties and included in living projects that emphasise their dual value: decorative and functional.

They are designed by designers with different languages and reveal the continuity of a research that combines quality, experience and passion for a new and more conscious lifestyle.



COLLEZIONE NATEVO  
NATEVO COLLECTION



ALBA LAMPADE DA TAVOLO TABLE LAMPS



CONTINUUM SCRITTOIO DESK



FILO ROSSO LAMPADE DA TAVOLO TABLE LAMPS



ARNO LAMPADE DA TAVOLO E DA TERRA TABLE AND FLOOR LAMPS



ARNO SEDIA CHAIR



KARA MOBILE MAKE-UP MAKE-UP UNIT



PEAK CONSOLLE CONSOLE



ASHAA LAMPADA DA TERRA FLOOR LAMP



BABELE LIBRERIA GIREVOLE SWIVEL BOOKCASE



RUGIADA LAMPADE DA TAVOLO E DA TERRA TABLE AND FLOOR LAMPS



SATURNO SPECCHIO MIRROR



BALLOON TAVOLO TABLE



BRISCOLA SEDIA CHAIR



SKI APPENDIABILI CLOTHES STAND



SOFTWING LAMPADE DA TAVOLO E DA TERRA TABLE AND FLOOR LAMPS

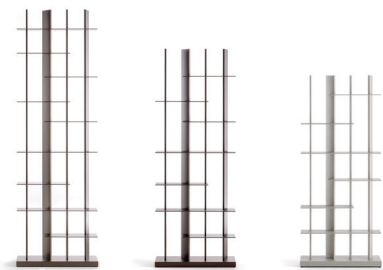

CCLIGHT LIBRERIA BOOKCASE



CHIARO DI LUNA COMODINO E LAMPADA BEDSIDE TABLE AND LAMP



STAAR LAMPADA DA TERRA FLOOR LAMP



TEKTON COLLEZIONE DI SEDUTE SEATING COLLECTION



Una lampada che ricrea la magia della luna e della sua luce impalpabile e diffusa. La sorgente luminosa è un LED a bassa tensione centrale racchiuso in un primo paralume in vetro borosilicato Pyrex® soffiato e sabbiato e in un secondo paralume che avvolge quasi completamente il primo, in vetro borosilicato Pyrex® con metallizzazione in finitura bronzato. Un gioco di volumi concentrici e di finiture che lascia filtrare una luce discreta, morbida e delicata. La base che sostiene i due paralumi è in metallo brunito opaco.

A lamp that recreates the magic of the moon and its impalpable, diffused light. The light source is a central low-voltage LED enclosed in a first lampshade in blown and sandblasted Pyrex® borosilicate glass and in a second lampshade that almost completely envelops the first, in Pyrex® borosilicate glass with a bronze finish metallisation.

An interplay of concentric volumes and finishes that lets a discreet, soft and delicate light filter through. The base supporting the two lampshades is in matt burnished metal.

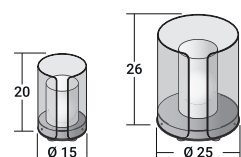

FINITURA FINISH	BRUNITO OPACO T013 MATT BURNISHED T013	
PARALUME ESTERNO EXTERNAL LAMP SHADE	VETRO BOROSILICATO PYREX® CON METALLIZZAZIONE IN FINITURA BRONZATO BOROSILICATE PYREX® GLASS WITH A METALLIC BRONZED FINISH	
PARALUME INTERNO INTERNAL LAMP SHADE	VETRO BOROSILICATO PYREX® SOFFIATO E SABBIATO BLOWN AND SANDED BOROSILICATE PYREX® GLASS	
ACCENSIONE LIGHT SWITCH TYPE	INTERRUTTORE A BILANCIERE BUTTON SWITCH ON/OFF	
	TELECOMANDO CON DIMMER REMOTE CONTROL WITH DIMMER	
	CASAMBI	
	Ø 15	Ø 25
POTENZA ALLACCIATA CONNECTED POWER	4,4 W	100 W
TEMPERATURA COLORE COLOR TEMPERATURE	2700 K	2700 K
FLUSSO LUMINOSO LIGHT FLUX	400 LM	1100 LM
TENSIONE TENSION	220 V EU / 110 V US	220 V EU / 110 V US
GRADO DI PROTEZIONE PROTECTION LEVEL	IP 20	IP 20

**ALBA**  
DESIGN ILENIA VISCARDI





La poltroncina Arno abbina alla struttura in metallo curvato essenziale e leggera la ricchezza esclusiva della pelle intrecciata e traforata dello schienale.

Una lavorazione mutuata dalla tradizione che gioca in forte contrasto con la contemporaneità della forma, per arrivare a un prodotto estremamente ricercato.

Telaio in metallo verniciato brunito opaco e seduta imbottita con rivestimento sfoderabile in tessuto o pelle. Lo schienale reclinabile ha il profilo in metallo verniciato come il telaio ed è rivestito in pelle a intreccio. Dettagli dei braccioli in pelle nello stesso colore dello schienale.

The Arno armchair combines the simple lightweight curved metal structure with the exclusive luxury of the punched woven leather of the backrest.

The manufacturing procedure was borrowed from traditional techniques and is in complete contrast with the contemporary shape - the result is an extremely stylish article.

Matt burnished metal frame and upholstered seat with removable fabric or leather cover. The backrest, like the frame, is trimmed in coated metal and covered with woven leather. Details of the leather armrests in the same colour as the backrest.

## ARNO

DESIGN MATTEO NUNZIATI

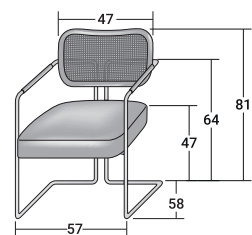

STRUTTURA STRUCTURE	BRUNITO OPACO T013 MATT BURNISHED T013
SCHIENALE BACKREST	PELLE INTRECCIATA WOVEN LEATHER
SEDUTA SEAT	TESSUTO O PELLE FBRIC OR LEATHER





È la pelle la protagonista delle lampade Arno, materiale decisamente inconsueto per questa tipologia di prodotto.

Il paralume è realizzato recuperando l'antica ed elaborata tecnica di lavorazione conciaria a intreccio ed è sostenuto da una struttura metallica che risulta essere, in contrasto, lineare, pulita ed essenziale. Sia nella versione da terra che in quella da tavolo, la lampada Arno è un oggetto raffinato ma assolutamente contemporaneo ed esprime tutta la sua preziosità nei dettagli e nella sapiente manifattura.

La struttura è in ferro verniciato con polvere epossidica color brunito opaco e il paralume è in pelle intrecciata. Paralume interno in vetro pirex sabbato.

Leather is the protagonist of the lamp Arno, an undoubtedly unusual material for this type of product.

The shade has been created using an ancient tanning process and it contrasts beautifully with the clear simple and linear metal frame. For both the standard and table versions, the lamp Arno is elegant and undeniably contemporary, expressing all the intrinsic value of the article in the details and the skills applied in the manufacture.

The structure is made of iron painted with matt burnished epoxy powder and the shade is woven leather. The inner shade liner is sanded Pyrex glass.

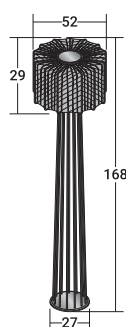
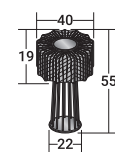

FINITURA FINISH	BRUNITO OPACO T013 MATT BURNISHED T013	
PARALUME LAMP SHADE	PELLE INTRECCIATA WOVEN LEATHER	
	LAMPADA DA TAVOLO H55 TABLE LAMP H55	LAMPADA DA TERRA H168 FLOOR LAMP H168
ACCENSIONE LIGHT SWITCH TYPE	INTERRUTTORE ON/OFF BUTTON SWITCH ON/OFF	INTERRUTTORE A PEDALE ON/OFF ON/OFF FOOT PEDAL CONTROL
POTENZA ALLACCIATA CONNECTED POWER	11 W	11 W
TEMPERATURA COLORE COLOR TEMPERATURE	2700 K	2700 K
FLUSSO LUMINOSO LIGHT FLUX	1521 LM	1521 LM
TENSIONE TENSION	240 - 220 V	240 - 220 V
GRADO DI PROTEZIONE PROTECTION LEVEL	IP 20	IP 20

**ARNO**  
DESIGN MATTEO NUNZIATI

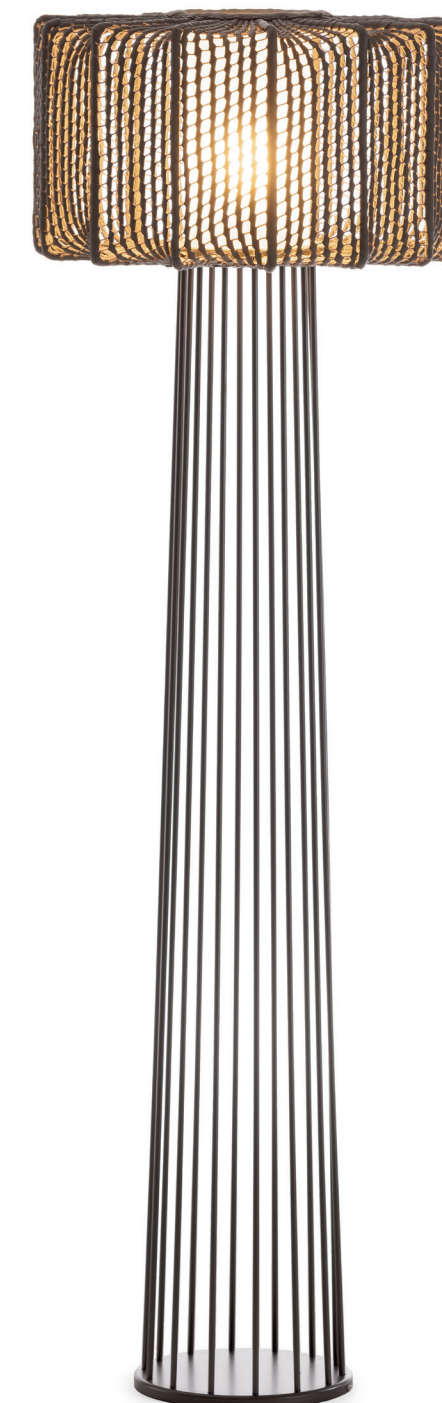

Cattura la scena la lampada da terra Ashaa dalla forte valenza arredativa. La struttura, formata da otto snelle doghe in legno curvato, si innalza inglobando e sorreggendo nella parte centrale una grande sfera di cristallo. Le strisce lignee e il top incorporano LED che, interagendo con il cristallo, creano effetti luminosi magici e sorprendenti.

La lampada è disponibile in rovere tinto caffè con sfera in vetro - trasparente, fumé o bronzo - posizionata nella metà superiore o nella metà inferiore.

The standard lamp Ashaa is extremely eye-catching and makes a strong furnishing statement. The structure is formed by eight slim slats in curved wood; it extends upwards, surrounds and supports in the central part a crystal ball. The LED strips, inserted in the wooden slats and in the metal top, interact with the crystal to create magical and surprising lighting effects.

The lamp is available in coffee-stained oak with a glass sphere - transparent, smoked or bronze - positioned in the upper or lower half.

**ASHAA**  
DESIGN STEFANO BIGI

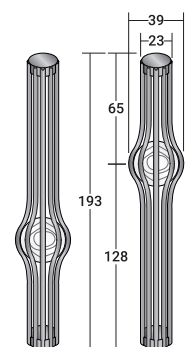

FINITURA FINISH	ROVERE CAFFÈ N081 COFFEE-BROWN OAK N081
SFERA SPHERE	VETRO TRASPARENTE N040 - VETRO FUMÉ N039 - VETRO BRONZATO N038 CLEAR GLASS N040 - SMOKED GLASS N039 - BRONZED GLASS N038
ACCENSIONE LIGHT SWITCH TYPE	INTERRUTTORE A PEDALE ON/OFF ON/OFF FOOT PEDAL CONTROL
	TELECOMANDO CON DIMMER REMOTE CONTROL WITH DIMMER
	CASAMBI
POTENZA ALLACCIATA CONNECTED POWER	77 W
TEMPERATURA COLORE COLOR TEMPERATURE	2700 K
FLUSSO LUMINOSO LIGHT FLUX	8041 lm
TENSIONE TENSION	220 V EU / 110 V US
GRADO DI PROTEZIONE PROTECTION LEVEL	IP 20





Di forma piacevolmente arrotondata, questa libreria girevole ha quattro ripiani orizzontali e divisori verticali di profondità diverse studiati per riporre adeguatamente libri, vasi e oggetti d'affezione. La struttura in metallo (finitura anodico bronzo) e legno (rovere tinto caffè) incorpora al centro una colonna dotata di LED che oltre a illuminare funge da asse di rotazione. Babele ha una linea apparentemente semplice ma estremamente sofisticata, è un oggetto prezioso realizzato con particolari tecniche di lavorazione, soluzioni costruttive all'avanguardia e accorgimenti studiati per garantire la sua perfetta stabilità.

With its pleasantly rounded shape, this swivel bookcase has four horizontal shelves and vertical dividers of different depths, which were designed to store books, vases and favorite ornaments. The structure in metal (anodic bronze) and wood (coffee-colored-stained oak) incorporates a central column fitted with LED lights, which, in addition to providing light, acts as the 'axis of rotation'. Babele has apparently simple lines yet is extremely sophisticated; it is a precious furnishing accessory produced using special processes, avantgarde manufacturing techniques and with details studied to guarantee its stability.

**BABELE**  
DESIGN MATTEO NUNZIATI

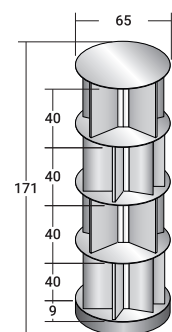

FINITURA FINISH	ROVERE TINTO CAFFÈ N081 COFFEE-BROWN-STAINED OAK N081
ACCENSIONE LIGHT SWITCH TYPE	INTERRUTTORE A PEDALE ON/OFF ON/OFF FOOT PEDAL CONTROL
	TELECOMANDO CON DIMMER REMOTE CONTROL WITH DIMMER
	CASAMBI
POTENZA ALLACCIATA CONNECTED POWER	73 W
TEMPERATURA COLORE COLOR TEMPERATURE	2700 K
FLUSSO LUMINOSO LIGHT FLUX	6570 LM
TENSIONE TENSION	220 V EU / 110 V US
GRADO DI PROTEZIONE PROTECTION LEVEL	IP 20



Si ispira alle forme della mongolfiera da cui prende il nome il tavolo caratterizzato dalla singolare struttura e dall'originale basamento in anodico bronze.

Il piano rotondo – disponibile nei due diametri 150 cm e 180 cm – può essere realizzato in tutte le tipologie di marmo della collezione Flou.

Ballon può essere completato con il vassoio girevole rotondo Lazy Susy.

This table has an unusual structure and an original base in anodic bronze and was inspired by the shape of a hot-air balloon.

The round top - available in the two diameters 150 cm and 180 cm - can be made of all marble types in the Flou collection.

Ballon can be completed with the Lazy Susy round revolving tray.

## BALLOON

DESIGN VOLODYMYR KARALYUS

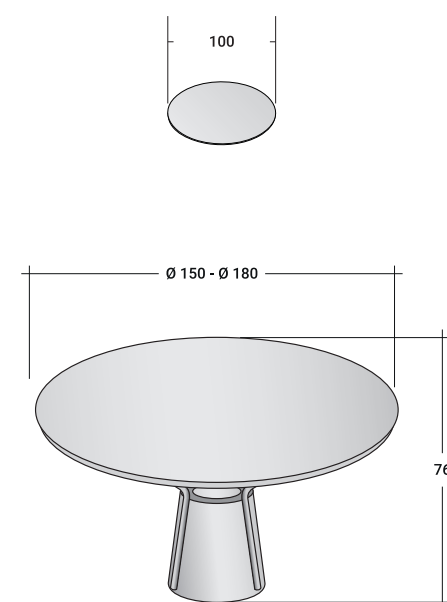

STRUTTURA STRUCTURE	ANODIC BRONZE T010
PIANO TOP	BIANCO DI CARRARA LUCIDO N060 CARRARA WHITE POLISHED N060
	EMPERADOR LUCIDO N064 EMPERADOR POLISHED N064
	OROBICO GRIGIO SPAZZOLATO OPACO N063 OROBICO GREY, MATT BRUSHED N063
	SILK GEORGETTE LUCIDO N068 SILK GEORGETTE POLISHED N068
	ARABESCO N070
	CALACATTA ORO LUCIDO N067 CALACATTA GOLD POLISHED N067
	IMPERO ROMANO N057





Pensata per essere accostata a ogni tipo di tavolo, la sedia Briscola ha un profilo sinuoso e avvolgente. Il comfort della seduta, assicurato da base e schienale costituiti da un unico guscio schiumato, la rendono inseribile in qualsiasi contesto. La linea tondeggiante, che contrasta con i tagli decisi del rivestimento, conferisce alla sedia un aspetto ricercato, con evidenti richiami al mondo dell'automotive. I dettagli sartoriali ingentiliscono il rigore della struttura in metallo. Il rivestimento dello schienale e della seduta è in tessuto o pelle completamente sfoderabile. La struttura è in metallo nelle finiture brunito opaco, anodico bronzo e greige opaco.

Thanks to its sinuous shape, the chair Briscola beautifully complements any type of table. Comfort is guaranteed by the seat and the backrest, consisting of a single foamed shell that matches any style. The pleasantly rounded lines contrast with the sharp cut of the upholstery, creating a stylish chair that was unmistakably inspired by the world of automobiles. Tailored details soften the sharpness of the metal structure. The upholstery of the backrest and seat is in fully removable fabric or leather. The structure is made of metal in matt burnished, anodic bronze and matt greige finishes.

**BRISCOLA**  
DESIGN PINUCCIO BORGONOVO

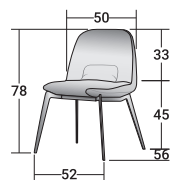

STRUTTURA STRUCTURE	BRUNITO OPACO T013 MATT BURNISHED T013 ANODIC BRONZE T010 GREIGE OPACO T019 MATT GREIGE T019
SEDUTA SEAT	TESSUTO O PELLE FBRIC OR LEATHER

La libreria CCLight è il perfetto esempio di come la luce possa donare all'ambiente leggerezza, atmosfera e un tocco di magia. Il primo e terzo montante inseriscono LED che, accesi, disegnano forme suggestive e diffondono una quantità di luce equivalente a quella di una lampada da terra.

La snella ed elegante struttura in profilato di alluminio si coniuga a una grande funzionalità.

La libreria è disponibile in diverse altezze e nei colori: bianco, nero, brunito opaco, anodic bronze, greige opaco, oxide, silver oxide e desert rock.

The bookcase CCLight is the perfect example of how light can inject a sense of airiness, a special atmosphere and a touch of magic into the ambient. The LEDs are inserted into the first and the third uprights. When switched on, they create suggestive shapes and emit a quantity of light equivalent to a standard lamp. The slim, elegant aluminium structure is joined by maximum function.

The bookcase is available in different heights and in the following colours: white, black, matt burnished, anodic bronze, matt greige, oxide, silver oxide and desert rock.

CCLIGHT  
DESIGN CARLO COLOMBO

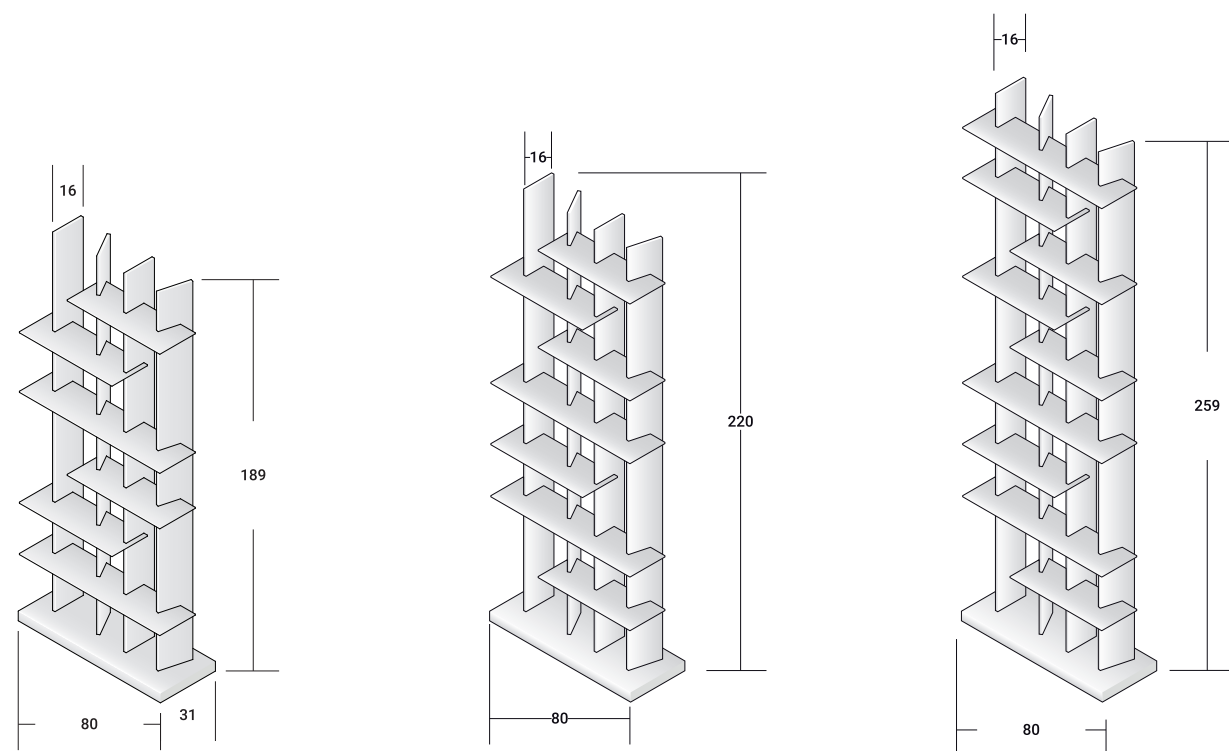

FINITURA FINISH	BIANCO OPACO T011 MATT WHITE T011
	NERO OPACO T012 MATT BLACK T012
	GREIGE OPACO T019 MATT GREIGE T019
	BRUNITO OPACO T013 MATT BURNISHED T013
	ANODIC BRONZE T010
	OXIDE T032
	SILVER OXIDE T033
	DESERT ROCK T029
ACCENSIONE LIGHT SWITCH TYPE	INTERRUTTORE A PEDALE ON/OFF ON/OFF FOOT PEDAL CONTROL
	TELECOMANDO CON DIMMER REMOTE CONTROL WITH DIMMER
	CASAMBI

	H189	H220	H259
POTENZA ALLACCIATA CONNECTED POWER	31 W	35 W	42 W
TEMPERATURA COLORE COLOR TEMPERATURE	3000 K	3000 K	3000 K
FLUSSO LUMINOSO LIGHT FLUX	5332 LM	6020 LM	7224 LM
TENSIONE TENSION	220 V EU / 110 V US	220 V EU / 110 V US	220 V EU / 110 V US
GRADO DI PROTEZIONE PROTECTION LEVEL	IP 20	IP 20	IP 20

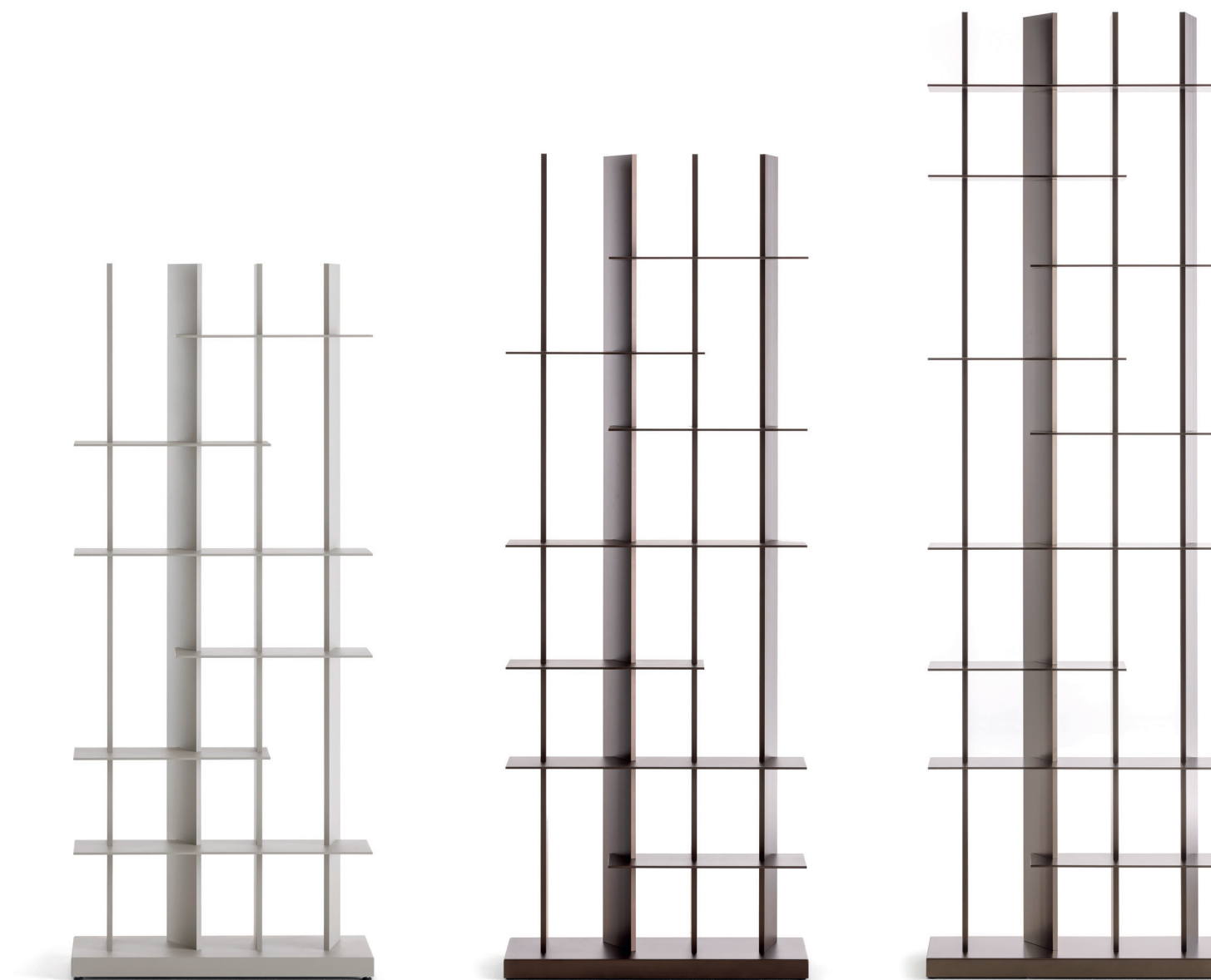



Comodino e al tempo stesso lampada, Chiaro di Luna è funzionale e pratico: offre due comodi piani di appoggio in vetro bronzato, uno dei quali – quello inferiore – incorpora i LED illuminanti.

La forma è cilindrica a ricordare quella della luna piena con le sue magiche luci; la struttura è realizzata in una speciale rete metallica che lascia irradiare la luce dal basso verso l'alto creando suggestivi giochi di luce e ombra: non una luce diretta e abbagliante ma calda, che arreda e che ben si adatta all'intimità della camera da letto.

Bedside table and lamp at the same time, Chiaro di Luna is both functional and practical: it offers two convenient bronzed glass shelves, one of which - the lower one - incorporates illuminating LEDs.

The cylindrical shape recalls the shape of the full moon with its magical lights; the frame is made of a special metal mesh that lets the light radiate from the bottom to the top, creating light and shadow effects that are full of charm: not a direct and dazzling light, but a warm one that decorates and is perfectly suitable for bedroom intimacy.

**CHIARO DI LUNA**  
DESIGN ILENIA VISCARDI

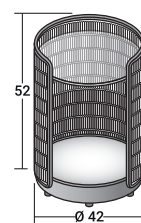

FINITURA FINISH	BIANCO OPACO T011 MATT WHITE T011 NERO OPACO T012 MATT BLACK T012 GREIGE OPACO T019 MATT GREIGE T019 BRUNITO OPACO T013 MATT BURNISHED T013 ANODIC BRONZE T010
PIANO TOP	VETRO BRONZATO N038 BRONZE GLASS N038
ACCENSIONE LIGHT SWITCH TYPE	INTERRUTTORE A BILANCIERE BUTTON SWITCH ON/OFF
	TELECOMANDO CON DIMMER REMOTE CONTROL WITH DIMMER
	CASAMBI
POTENZA ALLACCIATA CONNECTED POWER	13 W
TEMPERATURA COLORE COLOR TEMPERATURE	2700 K
FLUSSO LUMINOSO LIGHT FLUX	1092 LM
TENSIONE TENSION	220 V EU / 110 V US
GRADO DI PROTEZIONE PROTECTION LEVEL	IP 20

Moderno e sofisticato, lo scrittoio-scrivania Continuum è pensato sia per contesti domestici che professionali.

La sua linea semplice e decisa è caratterizzata dalla barra superiore orientabile con LED incorporati, in grado di illuminare la superficie del piano di lavoro.

La struttura in alluminio è offerta in due finiture (anodico bronze o gris sablé), mentre il piano di lavoro può essere scelto in rovere tinto caffè o nelle particolari finiture termostrutturate antigraffio in vari colori.

Nella versione "vanity" la barra orientabile dello scrittoio è arricchita da uno specchio rotondo.

Modern and sophisticated, the Continuum desk-desk is designed for both domestic and professional settings environments.

Its simple, cutting-edge lines are characterised by an adjustable bar above the top, with incorporated LED lights that illuminate the worktop surface. The aluminium structure is available in two finishes (anodic bronze or gris sablé); the worktop is available in coffee-brown oak, as well as in a choice of special heat-structured scratchproof finishes in various colours.

In the 'vanity' version the adjustable bar with integrated LED lights that lies above the top is embellished with a round mirror.

## CONTINUUM

DESIGN MATTEO NUNZIATI

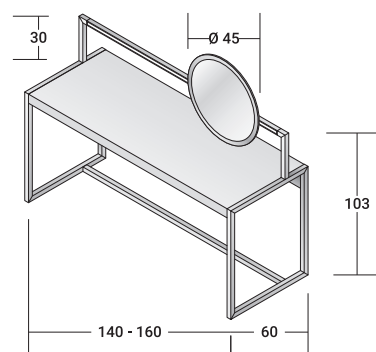
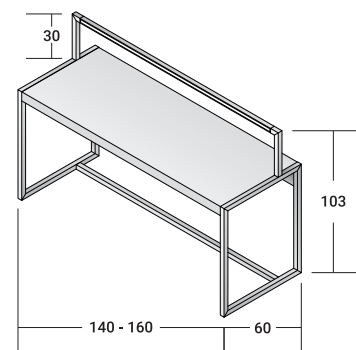

FINITURA FINISH	ANODIC BRONZE T010	
	GRIS SABLÉ 012	
PIANO TOP	ROVERE TINTO CAFFÈ N081	
	COFFEE-BROWN-STAINED OAK N081	
	STYLE SABBIA N012	
	STYLE SAND N012	
	EPOQUE BIANCO N051	
EPOQUE WHITE N051		
EPOQUE GREY N052		
EPOQUE GREY N052		
ACCENSIONE LIGHT SWITCH TYPE	INTERRUTTORE ON/OFF	
	BUTTON SWITCH ON/OFF	
	CASAMBI	
	L140	L160
POTENZA ALLACCIATA CONNECTED POWER	18 W	20 W
TEMPERATURA COLORE COLOR TEMPERATURE	2700 K	2700 K
FLUSSO LUMINOSO LIGHT FLUX	1360 LM	1530 LM
TENSIONE TENSION	220 V EU / 110 V US	220 V EU / 110 V US
GRADO DI PROTEZIONE PROTECTION LEVEL	IP 20	IP 20



Filo Rosso è una lampada da tavolo che abbina la forma più immediatamente associata alla luce – la classica lampadina – al legno della base, materiale raramente usato per l'illuminazione.

Trait d'union tra i due è, appunto, un "filo rosso" che con grande ironia e fantasia si trasforma da componente puramente funzionale a elemento decorativo e distintivo del progetto.

La base in massello di frassino finitura naturale o tinto caffè può avere forma conica o cubica.

Filo Rosso is a table lamp that combines the shape most immediately associated with light – the classic light bulb – with the wood of the base, a material that is seldom used for lighting.

The two elements are playfully joint by a "red thread", a purely functional component that, with great irony and imagination, becomes a decorative and distinctive feature.

The base in solid ash with a natural or coffee-stained finish can be conical or cubic.

## FILO ROSSO

DESIGN STEFANO BIGI

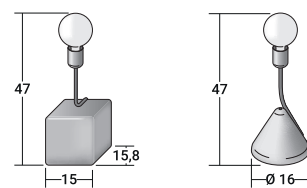

FINITURA FINISH	FRASSINO NATURALE N074 NATURAL ASH WOOD N074  FRASSINO TINTO CAFFÈ N076 COFFEE-BROWN-STAINED ASH WOOD N076
ACCENSIONE LIGHT SWITCH TYPE	INTERRUTTORE ON/OFF ON/OFF SWICHT
POTENZA ALLACCIATA CONNECTED POWER	8 W
TEMPERATURA COLORE COLOR TEMPERATURE	3000 K
FLUSSO LUMINOSO LIGHT FLUX	1055 LM
TENSIONE TENSION	240 - 220 V
GRADO DI PROTEZIONE PROTECTION LEVEL	IP 20



Mobile seducente destinato a un pubblico sensibile, esigente e sofisticato.

Kara è una raffinata toeletta a quattro cassetti con un sinuoso piano in prezioso marmo Calacatta oro da cui si elevano sette diversi specchi orientabili che racchiudono nella cornice LED in grado di diffondere una magica luminosità. Maniglie, profili e sostegni degli specchi sono in finitura oro anticato.

A seductive piece of furniture developed for clients who are sensitive, demanding and sophisticated. Kara is an elegant make-up desk, complete with four drawers and a sinuous gold Calacatta marble top, surrounded by seven adjustable mirrors with integrated LEDs that emit magical luminosity.

An antiqued gold finish for the handles, trim and the mirror supports.

**KARA**  
DESIGN TONER

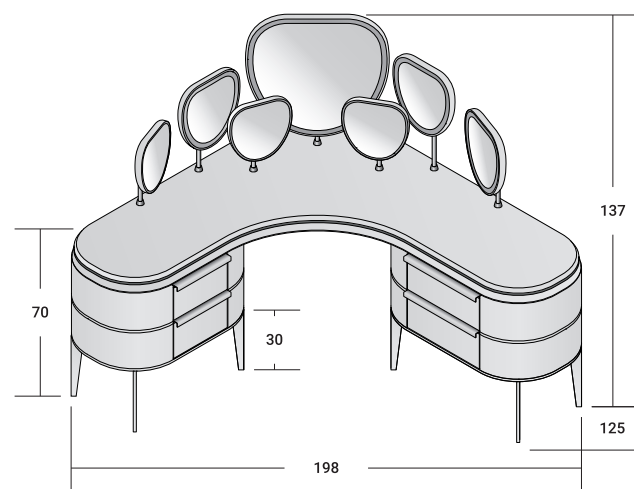

FINITURA FINISH	EBANO OPACO N089 - ORO ANTICATO MATT EBONY N089 - ANTIQUED GOLD
PIANO TOP	CALACATTA ORO LUCIDO N067 POLISHED CALACATTA GOLD N067
ACCENSIONE LIGHT SWITCH TYPE	INTERRUTTORE ON/OFF BUTTON SWITCH ON/OFF  CASAMBI
POTENZA ALLACCIATA CONNECTED POWER	48 W
TEMPERATURA COLORE COLOR TEMPERATURE	2700 K
FLUSSO LUMINOSO LIGHT FLUX	4140 LM
TENSIONE TENSION	220 V EU / 110 V US
GRADO DI PROTEZIONE PROTECTION LEVEL	IP 20



Di gusto contemporaneo, lo specchio/consolle Peak rivitalizza e illumina zone di passaggio spesso trascurate come l'ingresso e l'anticamera. È un punto d'appoggio ma anche una fonte luminosa grazie ai LED inseriti nella struttura.

Il grande specchio rettangolare è interrotto da un ripiano in prezioso marmo Orobico grigio spazzolato, tagliato in modo da esaltarne le caratteristiche venature. Il ripiano, in alternativa, è disponibile anche in vetro nero o in vetro extra chiaro.

The contemporary style of the mirror/console Peak revitalizes and illuminates transition areas in the home – such as the entrance lobby and the hall – areas that are often ignored. Used as a surface to place items, it is also a light source thanks to the LEDs integrated in the structure.

The large rectangular mirror is intersected by a luxurious shelf in brushed Orobico grey marble, cut to exalt its characteristic veining. Alternately, the shelf is available in black or extra-clear glass.

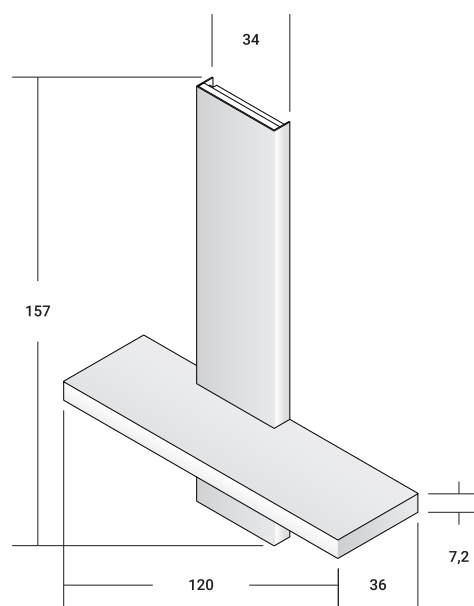
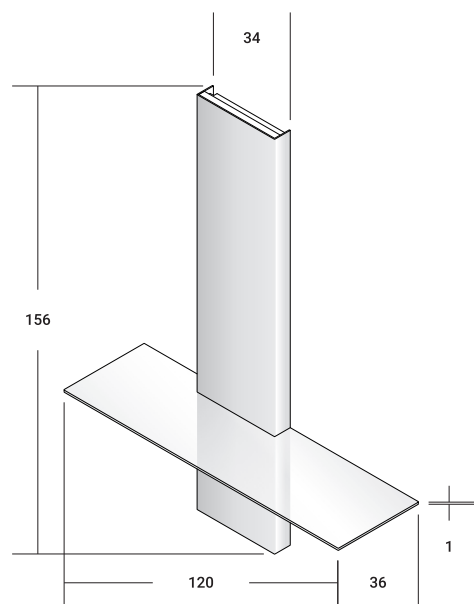

FINITURA FINISH	SPECCHIO MIRROR
PIANO TOP	OROBICO GRIGIO SPAZZOLATO OPACO N063 OROBICO GREY MATT BRUSHED N063
	VETRO NERO BLACK GLASS VETRO EXTRA CHIARO EXTRA CLEAR GLASS
ACCENSIONE LIGHT SWITCH TYPE	INTERRUTTORE ON/OFF BUTTON SWITCH ON/OFF
	TELECOMANDO CON DIMMER REMOTE CONTROL WITH DIMMER
	CASAMBI
POTENZA ALLACCIATA CONNECTED POWER	53 W
TEMPERATURA COLORE COLOR TEMPERATURE	2700 K
FLUSSO LUMINOSO LIGHT FLUX	4770 LM
TENSIONE TENSION	220 V EU / 110 V US
GRADO DI PROTEZIONE PROTECTION LEVEL	IP 20



**PEAK**  
DESIGN PINUCCIO BORGONOVO



Rugiada è una lampada da appoggio dal disegno semplice e regolare, così come sono gli elementi che la compongono: una sfera e una linea. La forma perfetta della sfera crea la base mantenendo il più possibile l'originalità della materia: il legno massello con in evidenza le sue fibre, o il vetro soffiato che con i suoi riflessi porta in sé l'immagine dell'ambiente in cui è posto.

Il corpo illuminante è un'asta obliqua priva di ogni elemento decorativo superfluo; ospita la luce senza dominarla e crea un equilibrio di forma unico, disegnando lo spazio con raffinata leggerezza.

Rugiada is a table or floor lamp with a simple symmetrical design, just like the elements used in its creation: a sphere and a line. The perfect shape of the sphere creates the base while maintaining as much of the originality of the materials as possible: the exposed fibres of the heartwood, or the reflections of blown glass that carry images of the surroundings.

The light fitting is an oblique shaft that is void of any unnecessary decorative element; it houses the light without overpowering it and creates a unique balance of shape, defining the space with elegant lightness.

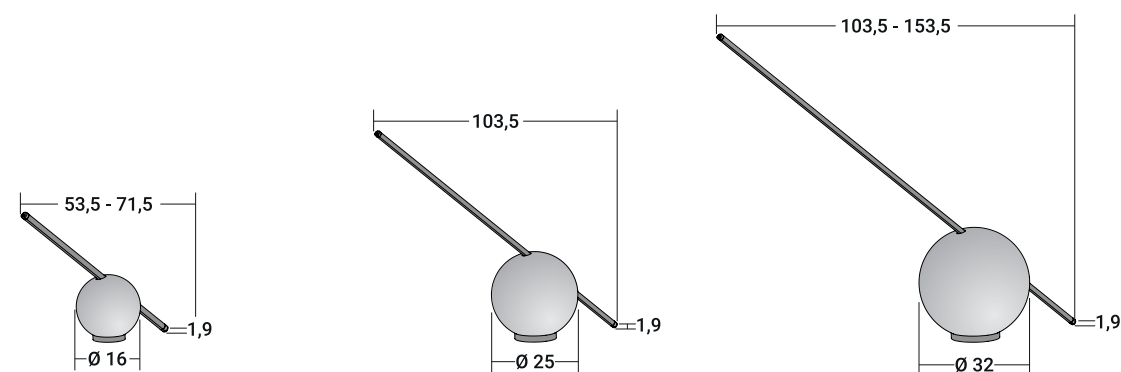

FINITURA FINISH	FRASSINO NATURALE N074 NATURAL ASH WOOD N074
	FRASSINO TINTO CAFFÈ N076 COFFEE-BROWN-STAINED-ASH WOOD N076
ACCENSIONE LIGHT SWITCH TYPE	VETRO TRASPARENTE N040 CLEAR GLASS N040
	VETRO FUMÉ N039 SMOKED GLASS N039
	VETRO BRONZATO N038 BRONZED GLASS N038
	VETRO NICKEL NERO 003N BLACK NICKEL GLASS 003N
	VETRO BRUNITO OPACO 003B MATT BURNISHED GLASS 003B
	INTERRUTTORE ON/OFF BUTTON SWITCH ON/OFF
	CASAMBI CASAMBI

	LED L.53,5	LED L.71,5	LED L.103,5	LED L.153,5
POTENZA ALLACCIATA CONNECTED POWER	5 W	5 W	10 W	15 W
TEMPERATURA COLORE COLOR TEMPERATURE	2700 K	2700 K	2700 K	2700 K
FLUSSO LUMINOSO LIGHT FLUX	450 LM	608 LM	900 LM	1350 LM
TENSIONE TENSION	220 V EU / 110 V US	220 V EU / 110 V US	220 V EU / 110 V US	220 V EU / 110 V US
GRADO DI PROTEZIONE PROTECTION LEVEL	IP 20	IP 20	IP 20	IP 20

**RUGIADA**  
DESIGN ILENIA VISCARDI

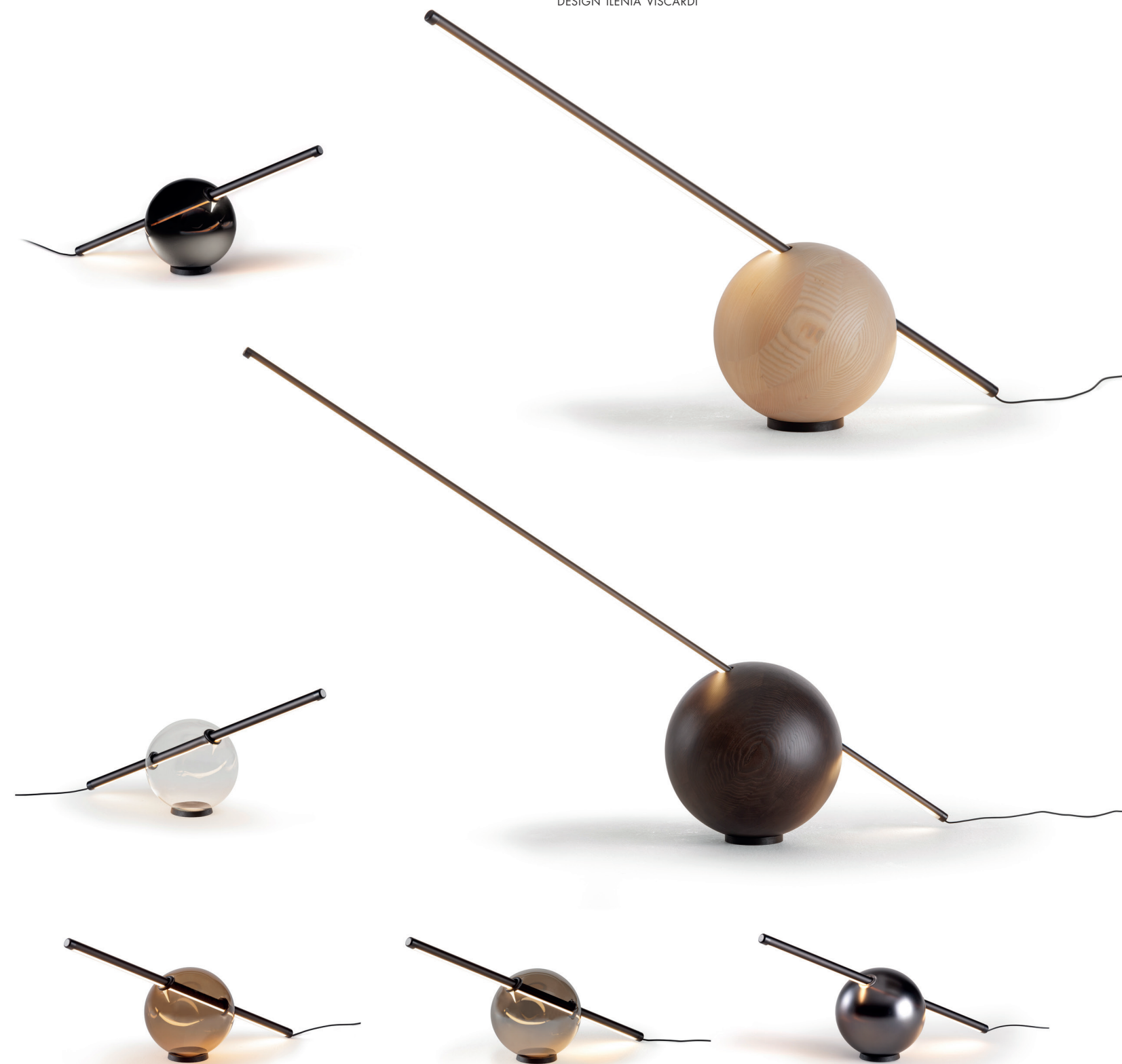

Maestoso specchio ovoidale, montabile sia verticalmente che orizzontalmente, ideale per conferire prestigio a grandi spazi, hall di alberghi e dimore importanti.

La struttura in Baydur®, ottenuta da stampo, può essere scelta in due versioni altrettanto eleganti: grafite e bronzato. Il cristallo dello specchio in tre varianti: naturale, fumé, bronzato.

Lo specchio è retroilluminato a LED interposti tra cornice e parte specchiante, con effetti particolarmente suggestivi.

A majestic oval-shaped mirror, that can be positioned vertically or horizontally, is the ideal accessory to add prestige to large spaces, hotel lobbies and important mansions.

The molded structure in Baydur® is available in two equally elegant versions: graphite and bronze. The mirror crystal in three variants: natural, smoked, bronzed.

The mirror is backlit with LED lights integrated between the frame and the mirror pane, and this produces unusually suggestive effects.

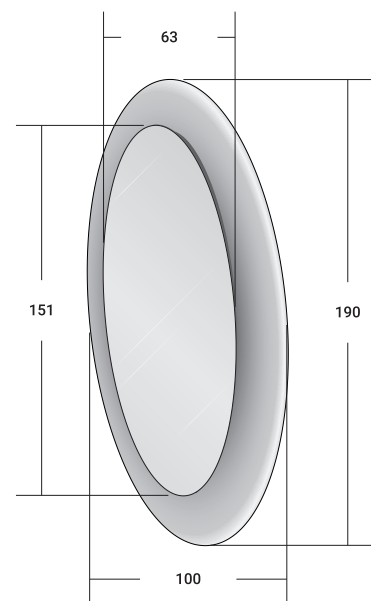

FINITURA FINISH	GRAFITE GRAPHITE BRONZATO BRONZED
ACCENSIONE LIGHT SWITCH TYPE	INTERRUTTORE A PEDALE ON/OFF ON/OFF FOOT PEDAL CONTROL
	TELECOMANDO CON DIMMER REMOTE CONTROL WITH DIMMER
	CASAMBI
POTENZA ALLACCIATA CONNECTED POWER	38 W
TEMPERATURA COLORE COLOR TEMPERATURE	2700 K
FLUSSO LUMINOSO LIGHT FLUX	3400 LM
TENSIONE TENSION	220 V EU / 110 V US
GRADO DI PROTEZIONE PROTECTION LEVEL	IP 20

**SATURNO**  
DESIGN MATTEO NUNZIATI





Ski nasce da una curiosa osservazione diretta: una sequenza di sci addossati alla parete di un rifugio e utilizzati come appendiabiti.

Le snelle doghe che lo compongono integrano LED e si aprono e si chiudono creando effetti luminosi suggestivi. È realizzato in legno massello di frassino nei colori bianco, nero, grafite.

Ski was born from a curious direct observation: a sequence of skis resting against a wall in a mountain lodge and used as clothes racks.

Ski consists of slim mobile slats with integrated LED lights, and can be opened and closed, creating suggestive luminous effects. It is produce of solid ash wood in the colours white, black, graphite.

**SKI**

DESIGN PINUCCIO BORGONOVO

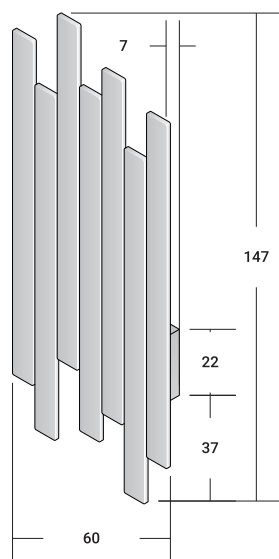
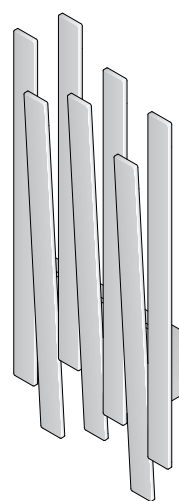

FINITURA FINISH	FRASSINO TINTO BIANCO WHITE-STAINED ASHWOOD FRASSINO TINTO NERO BLACK-STAINED ASHWOOD FRASSINO TINTO GRAFITE GRAPHITE-STAINED ASHWOOD
ACCENSIONE LIGHT SWITCH TYPE	INTERRUTTORE ON/OFF SWITCH ON/OFF  CASAMBI
POTENZA ALLACCIATA CONNECTED POWER	9 W
TEMPERATURA COLORE COLOR TEMPERATURE	3500 K
FLUSSO LUMINOSO LIGHT FLUX	720 LM
TENSIONE TENSION	220 V EU / 110 V US
GRADO DI PROTEZIONE PROTECTION LEVEL	IP 20





Un dettaglio funzionale che è quasi una magia caratterizza la lampada Softwing: grazie a un sensore si accende semplicemente sfiorandola delicatamente con un dito. Elegante e sofisticata sia nella versione da terra che in quella da tavolo, è realizzata con materiali di pregio: acciaio per i due elementi di supporto (finiture brunito opaco o anodico bronze), vetro soffiato per la sfera luminosa (finiture trasparente, fumé o color bronzo), cuoio per il disco di copertura della base.

A functional, almost magical detail characterises the lamp Softwing: thanks to a sensor the lamp is activated with a light touch of the hand. Both the standard and table lamp versions are elegant and sophisticated, and produced exclusively with top quality materials: steel for the two support elements (with a choice of matt burnished or anodic bronze finish), blown glass for the luminous ball (with a choice of clear, smoked or bronze glass), hide for the disk that covers the base.

**SOFTWING**  
DESIGN CARLO COLOMBO

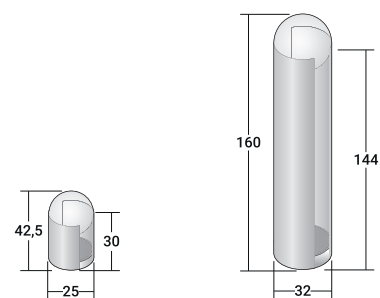

FINITURA FINISH	BRUNITO OPACO T013 MATT BURNISHED T013 ANODIC BRONZE T010	
SFERA SPHERA	VETRO TRASPARENTE N040 TRASPARENT GLASS N040 VETRO FUMÉ N039 SMOKED GLASS N039 VETRO BRONZATO N038 BRONZED GLASS N038	
ACCENSIONE LIGHT SWITCH TYPE	INTERRUTTORE A PEDALE ON/OFF ON/OFF FOOT PEDAL CONTROL CASAMBI	
	LAMPADA DA TAVOLO H30 TABLE LAMP H30	LAMPADA DA TERRA H144 FLOOR LAMP H144
POTENZA ALLACCIATA CONNECTED POWER	16 W	41 W
TEMPERATURA COLORE COLOR TEMPERATURE	2700 K	2700 K
FLUSSO LUMINOSO LIGHT FLUX	1050 LM	4200 LM
TENSIONE TENSION	240 - 220 V EU / 110 V US	240 - 220 V EU / 110 V US
GRADO DI PROTEZIONE PROTECTION LEVEL	IP 20	IP 20



Una lampada da terra che prima di tutto stupisce per la sua capacità di arredare. Importante nelle dimensioni e pregiata nella lavorazione del legno massello, ha una forma "a stella" che rimanda immediatamente all'idea universale di luce e calore.

La struttura in frassino tinto caffè incorpora con eleganza i paralumi in policarbonato accoppiato a pergamena e i LED illuminanti.

A floor lamp that first of all impresses with its furnishing capacity. Significant in size and fine solid wood workmanship, it has a 'star' shape that immediately evokes the universal idea of light and warmth.

The coffee-stained ash frame elegantly incorporates the parchment-lined polycarbonate lampshades and the illuminating LEDs.

**STAAR**  
DESIGN STEFANO BIGI

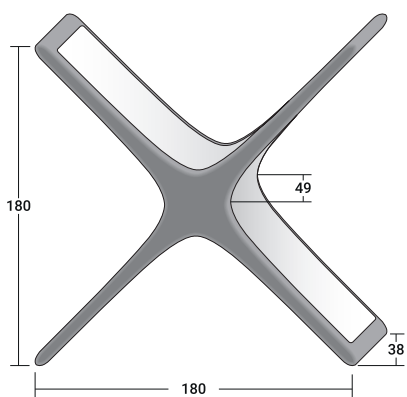

FINITURA FINISH	FRASSINO TINTO CAFFÈ N076 COFFEE-BROWN-STAINED ASHWOOD N076
ACCENSIONE LIGHT SWITCH TYPE	INTERRUTTORE A PEDALE ON/OFF ON/OFF FOOT PEDAL CONTROL  TELECOMANDO CON DIMMER REMOTE CONTROL WITH DIMMER  CASAMBI
POTENZA ALLACCIATA CONNECTED POWER	54 W
TEMPERATURA COLORE COLOR TEMPERATURE	2700 K
FLUSSO LUMINOSO LIGHT FLUX	12200 LM
TENSIONE TENSION	220 V EU / 110 V US
GRADO DI PROTEZIONE PROTECTION LEVEL	IP 20



Comfort ed eleganza ispirano le forme fluide e organiche delle sedie e poltroncine Tekton, capaci di integrarsi in qualsiasi contesto. Gli schienali e i braccioli sono realizzati in un unico pezzo di legno massello con finitura frassino tinto caffè. La forma parte dall'asse verticale dello schienale per raggiungere l'asse orizzontale dei braccioli grazie a un inedito raccordo a spirale.

In tre versioni:

- Tekton Naked sedia con schienale e braccioli in legno e seduta imbottita.
- Tekton poltroncina con schienale e braccioli in legno e seduta a guscio imbottita.
- Tekton sedia imbottita con seduta a guscio imbottita e senza schienale e braccioli in legno.

Comfort and elegance inspire the fluid, organic forms of the Tekton chairs and armchairs, which can be integrated into any context. The backrests and armrests are made from a single piece of solid wood with a coffee-brown ashwood finish. The shape starts from the vertical axis of the backrest and reaches the horizontal axis of the armrests thanks to an unusual spiral connection.

In three versions:

- Tekton Naked chair with wooden backrest and armrests and upholstered seat.
- Tekton armchair with wooden backrest and armrests and upholstered shell seat.
- Tekton upholstered chair with upholstered shell seat and no wooden backrest and armrests.

## TEKTON

DESIGN MATTEO NUNZIATI

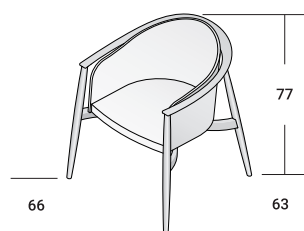
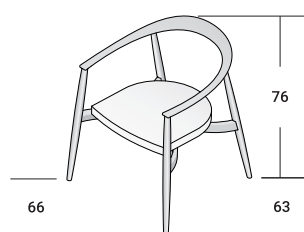
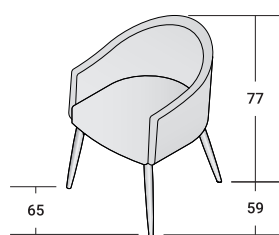

STRUTTURA STRUCTURE	FRASSINO TINTO CAFFÈ N076 COFFEE-BROWN ASHWOOD N076
SEDUTA SEAT	TESSUTO O PELLE FBRIC OR LEATHER



Progetti di case in cui i prodotti Natevo si integrano in maniera coerente alle proposte di arredo Flou portando in ogni ambiente la loro luce innata.

Home projects in which Natevo products integrate coherently with Flou's furnishing proposals, bringing their innate light into every room.

**NATEVO** | PROJECTS

# /01 OPEN SPACE

Un open-space all'insegna della flessibilità e della funzionalità. La luce naturale che fluisce liberamente negli spazi è rafforzata da quella diffusa dalle librerie modulari CCLight che si inseriscono con uguale facilità nel living e nella zona pranzo.

Una luce innata, funzionale ed estetica arricchisce anche lo scrittoio Continuum, dotato di una barra orientabile a led che illumina il piano di lavoro.

An open-plan space in the name of flexibility and functionality. The natural light flowing freely into the space is enhanced by that diffused by the modular CCLight bookcases, which fit into the living and dining area with equal ease.

An innate, functional and aesthetic light also enriches the Continuum desk, which is equipped with a swivelling LED bar that illuminates the worktop.

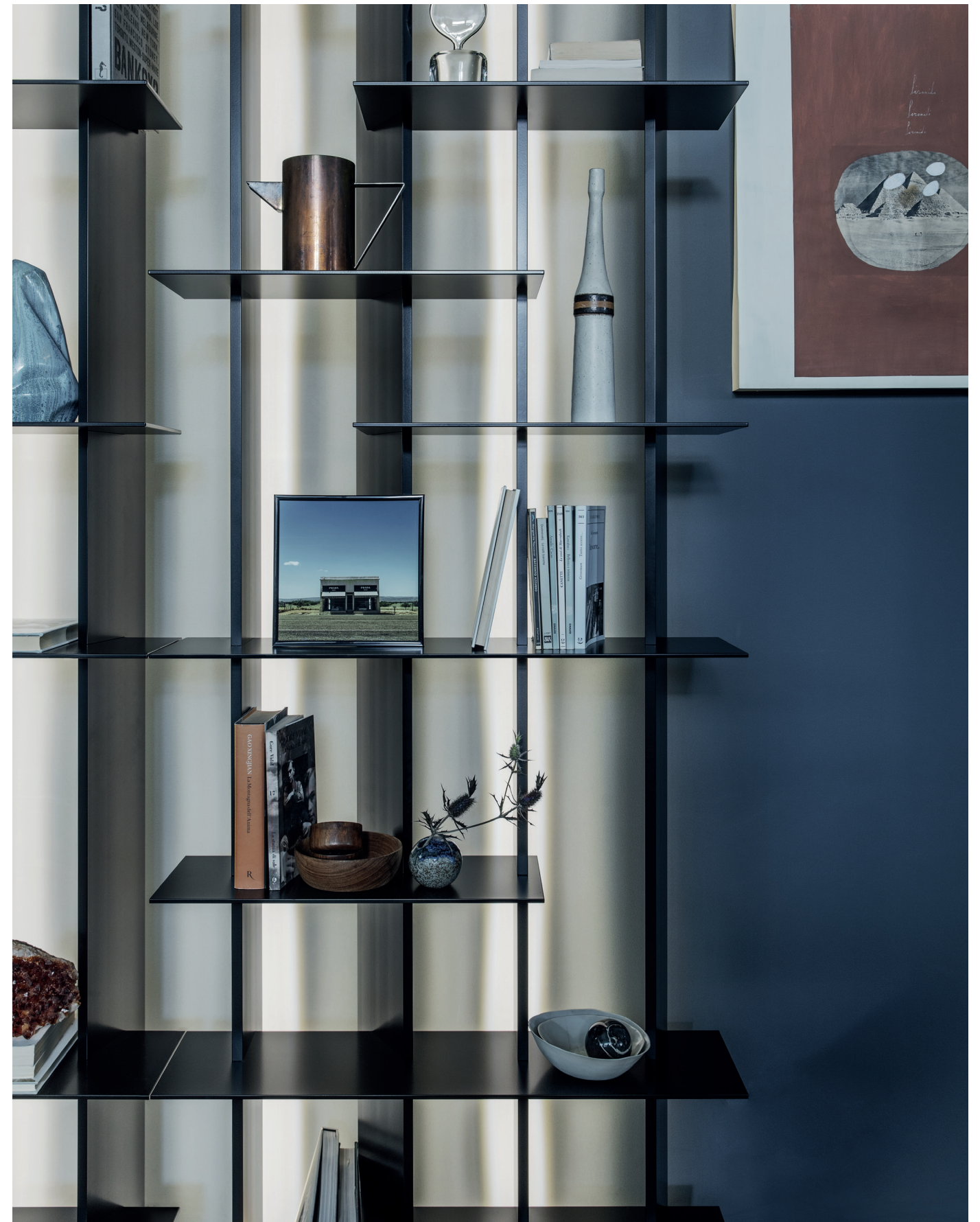





LIBRERIA CCLIGHT DESIGN C.COLOMBO, FINITURA NERO OPACO T012

BOOKCASE CCLIGHT DESIGNED BY C.COLOMBO, MATT BLACK FINISH T012





Nella zona pranzo le comode poltroncine Arno e il tavolo Balloon, con il piano e il conviviale Lazy Susy girevole in pregiato marmo Arabesco.

Le librerie CCLight completano e illuminano l'ambiente: la loro modularità intelligente le rende perfette sia per piccole nicchie che per grandi pareti.

In the dining area the comfortable Arno armchairs and the Balloon table, with the top and the swivel Lazy Susy in fine Arabesco marble.

The CCLight bookcases complete and illuminate the room: their intelligent modularity makes them perfect for both small niches and large walls.

LIBRERIA CCLIGHT DESIGN C.COLOMBO, FINITURA NERO OPACO T012  
TAVOLO BALLOON DESIGN V.KARALYUS, FINITURA ANODIC BRONZE T010,  
PIANO MARMO ARABESCO N080

SEDIA ARNO DESIGN M.NUNZIATI, FINITURA BRUNITO OPACO T013,  
SCHIENALE PELLE 127, SEDUTA NINA 751

BOOKCASE CCLIGHT DESIGNED BY C.COLOMBO, MATT BLACK FINISH T012  
TABLE BALLOON DESIGNED BY V.KARALYUS, ANODIC BRONZE FINISH T010,  
MARBLE TOP ARABESCO N080

ARMCHAIR ARNO DESIGNED BY M.NUNZIATI, MATT BURNISHED T013 FINISH,  
BACKREST LEATHER 127, SEAT NINA 751





Lo spazio del relax è costruito su una palette di colori morbida e delicata e il divano componibile Doze offre sedute accoglienti e profonde con tanti cuscini che lo rendono ancora più confortevole. Sulla parete di fondo i quattro moduli CCLight rafforzano la luce naturale creando suggestivi giochi di luci e ombre.

The relaxation space is built on a soft, delicate colour palette, and the sectional sofa Doze offers cosy, deep seating with plenty of cushions to make it even more comfortable. On the back wall, the four CCLight modules reinforce the natural light, creating suggestive plays of light and shadow.

LIBRERIA CCLIGHT DESIGN C.COLOMBO, FINITURA NERO OPACO T012

BOOKCASE CCLIGHT DESIGNED BY C.COLOMBO, MATT BLACK FINISH T012





Le poltroncine e il tavolino Iko definiscono l'angolo dell'accoglienza. Una collezione che abbina con eleganza la morbidezza del tessile al pregio del cuoio, del metallo e del marmo. La lampada da terra Rugiada fornisce il punto luce: una sfera in legno massello e un'asta obliqua in vetro soffiato che ospita la luce disegnando lo spazio con raffinata leggerezza.

The Iko armchairs and coffee table define the welcoming corner. A collection that elegantly combines the softness of textiles with the quality of leather, metal and marble. The Rugiada floor lamp provides the light point: a solid wood sphere and an oblique blown glass rod that houses the light, designing the space with refined lightness.



LAMPADA DA TERRA RUGIADA DESIGN I.VISCARDI, FRASSINO TINTO CAFFÈ N076

FLOOR LAMP RUGIADA DESIGNED BY I.VISCARDI, COFFEE-BROWN-STAINED ASHA WOOD N076





Linee pulite, eleganti e funzionali: la scrivania Continuum è dotata di luci LED per illuminare al meglio il piano di lavoro. Una perfetta postazione di home office completata dalla confortevole sedia Tekton.

Clean lines, elegant and functional: the Continuum desk is equipped with LED lights to optimally illuminate the work surface. A perfect home office workstation complemented by the comfortable Tekton chair.

SCRITTOIO CONTINUUM DESIGN M.NUNZIATI, FINITURA ANODIC BRONZE T010,  
TOP ROVERE TINTO CAFFÈ N081  
SEDIA IMBOTTITA TEKTON DESIGN M.NUNZIATI, STRUTTURA ROVERE CAFFÈ N081,  
SEDUTA A GUSCIO GREG 961

WRITING DESK CONTINUUM DESIGNED BY M.NUNZIATI, ANODIC BRONZE FINISH T010,  
TOP COFFEE-BROWN OAK N081  
PADDED CHAIR TEKTON DESIGNED BY M.NUNZIATI, STRUCTURE COFFEE-BROWN OAK N081,  
SEAT GREG 961





# /02

## URBAN LOFT

Un moderno loft urbano, una casa/studio dove abitare e lavorare e che diventa all'occorrenza anche set fotografico. Anche in questo caso i prodotti Natevo mostrano come la luce possa assumere forme inusuali, innovative e scultoree.

A modern urban loft, a home/studio where one can live and work and which also becomes a photographic set if necessary. Here again, Natevo products show how light can take on unusual, innovative and sculptural forms.







Kara è un mobile make-up seducente e sofisticato, con un sinuoso piano in marmo e sette specchi orientabili con LED per soddisfare ogni vanità. Trova una collocazione perfetta a fianco dell'altrettanto prezioso e ricercato letto matrimoniale Amal.

Kara is a seductive and sophisticated make-up cabinet, with a sinuous marble top and seven adjustable mirrors with LEDs to satisfy every vanity. It finds a perfect place alongside the equally precious and sought-after Amal double bed.

MOBILE MAKE-UP KARA DESIGN TONER, FINITURA EBANO OPACO N089 - TOP MARMO CALACATTA ORO LUCIDO N067  
COMODINO CHIARO DI LUNA DESIGN I.VISCARDI, FINITURA BRUNITO OPACO T013

MAKE-UP UNIT KARA DESIGNED BY TONER, MATTE EBONY N089 - TOP POLISHED CALACATTA GOLD MARBLE N067  
BEDSIDE TABLE CHIARO DI LUNA DESIGN I.VISCARDI, MATT BURSHED FINISH T013





MOBILE MAKE-UP KARA DESIGN TONER, FINITURA EBANO OPACO N089 - TOP MARMO CALACATTA ORO LUCIDO N067

MAKE-UP UNIT KARA DESIGNED BY TONER, MATTE EBONY N089 - TOP POLISHED CALACATTA GOLD MARBLE N067











Più che una lampada Staar è una vera scultura luminosa, che stupisce per la sua capacità di arredare e di caratterizzare ogni ambiente; in questo caso il living, arredato con il divano componibile MyPlace, la poltroncina Madame Butterfly e il tavolo di servizio Gaudí.

More than a lamp, Staar is a true luminous sculpture, astonishing in its ability to furnish and characterise any environment; in this case the living room, furnished with the modular MyPlace sofa, the Madame Butterfly armchair and the Gaudí service table.

LAMPADA STAAR DESIGN S.BIGI, FINITURA FRASSINO TINTO CAFFÈ N076

LAMP STAAR DESIGNED BY S.BIGI, COFFEE-BROWN-STAINED ASH WOOD N076





# /03

## MODERN HOUSE

Una casa moderna, dall'architettura pulita e rigorosa che si concede come unico e originale tocco di décor i grandi oblò che inondano ogni ambiente di luce naturale.

I prodotti Natevo scelti per questo progetto - le librerie CCLight, i comodini Chiaro di Luna, la lampada Filo Rosso - insieme alla luce portano negli ambienti un tocco di originalità e freschezza.

A modern house with neat and simple architecture, whose only peculiar decorative touch is represented by the large portholes that flood every room with natural light.

The Natevo products chosen for this project - the CCLight bookcases, the Chiaro di Luna bedside tables, the Filo Rosso lamp - together with the light bring a touch of originality and freshness to the rooms.







Nella master bedroom il letto matrimoniale Baia: alto da terra, leggero ma presente, con belle cuciture che sottolineano la curva morbida della testata. I comodini Chiaro di Luna incorporano LED nel piano inferiore in vetro e diffondono una luce notturna discreta e morbida che ben si addice all'intimità della camera.

In the master bedroom the Baia double bed: high from the floor, light but present, with beautiful stitching that emphasises the soft curve of the headboard. The Chiaro di Luna bedside tables incorporate LEDs in the lower glass top and diffuse a discreet and soft night light that is well suited to the intimacy of the room.



COMODINO CHIARO DI LUNA DESIGN I.VISCARDI, FINITURA BRUNITO OPACO T013

BEDSIDE TABLE CHIARO DI LUNA DESIGN I.VISCARDI, MATT BURSHED FINISH T013





LIBRERIA CCLIGHT DESIGN C.COLOMBO, FINITURA DESERT ROCK T029

BOOKCASE CCLIGHT DESIGNED BY C.COLOMBO, DESERT ROCK FINISH T029





Il punto luce a fianco del letto singolo Biss è Filo Rosso; una semplice lampadina sorretta da un filo che con fantasia ed ironia si trasforma da componente funzionale in elemento decorativo e distintivo del progetto.

The lighting point next to the Biss single bed is Filo Rosso; a simple light bulb supported by a wire that with imagination and irony is transformed from a functional component into a decorative and distinctive element of the design.

LAMPADA FILO ROSSO DESIGN S.BIGI, FINITURA FRASSINO NATURALE N074

LAMP FILO ROSSO DESIGNED BY S.BIGI, NATURAL ASH FINISH N074







Mimetizzata tra le piante del giardino d'inverno la lampada Ashaa è un connubio tra poesia e scultura, fatto di vetro, legno e luce. La sfera di cristallo diffonde in modo magico la luce dei LED inseriti nella struttura.

Camouflaged among the plants in the winter garden, the Ashaa lamp is a combination of poetry and sculpture, made of glass, wood and light. The crystal sphere magically diffuses the light of the LEDs embedded in the structure.

LAMPADA DA TERRA ASHAA DESIGN S.BIGI, FINITURA ROVERE CAFFÈ N081

STANDARD LAMP ASHAA DESIGNED BY S.BIGI, COFFEE-BROWN OAK FINISH N074







Peak è una consolle in grado di valorizzare ogni ingresso e ogni zona di passaggio. Illumina grazie ai LED inseriti nel grande specchio e dona un segno deciso e contemporaneo grazie al ripiano in marmo di forte spessore.

Peak is a console that can enhance any entrance and passage area. It illuminates thanks to the LEDs inserted in the large mirror and gives a strong, contemporary sign thanks to the thick marble shelf.

CONSOLE CON SPECCHIO PEAK DESIGN P.BORGONOVO, TOP MARMO OROBICO GRIGIO SPAZZOLATO OPACO N063

CONSOLE WITH MIRROR PEAK DESIGNED BY P.BORGONOVO, TOP BRUSHED OROBICO GREY MARBLE N063





La libreria Babele unisce decorazione e luce in angoli della casa spesso difficili da sfruttare. Dalla colonna centrale si diffonde una calda luce a LED che esalta lo spazio e gli oggetti contenuti.

The Babele bookcase combines decoration and light in corners of the home that are often difficult to exploit. A warm LED light spreads from the central column, enhancing the space and the objects it contains.

LIBRERIA GIREVOLE BABEL DESIGN M.NUNZIATI, FINITURA ANODIC BRONZE T010 - ROVERE CAFFÈ N081

SWIVEL BOOKCASE LAMP BABEL DESIGNED BY M.NUNZIATI, ANODIC BRONZE T010 - COFFEE-BROWN OAK FINISH N074







Tutto riconduce al relax in questa camera matrimoniale: dal letto Baia nella preziosa versione in pelle, all'avvolgente poltroncina Madame Butterfly fino ai comodini luminosi Chiaro di Luna, ispirati alla forma perfettamente sferica della luna e alla sua impalpabile materia.

Everything leads back to relaxation in this double bedroom: from the Baia bed in the precious leather version to the enveloping Madame Butterfly armchair to the luminous Chiaro di Luna bedside tables, inspired by the perfectly spherical shape of the moon and its impalpable material.

COMODINI CHIARO DI LUNA DESIGN I.VISCARDI, FINITURA BRUNITO OPACO T013

BEDSIDE TABLES CHIARO DI LUNA DESIGN I.VISCARDI, MATT BURSHED FINISH T013





# /04

## NATURAL HOUSE

Un rifugio segreto nascosto nel verde dell'Appennino Toscano. Gli spazi sono ampi e fluidi, arredati con pochi pezzi selezionati con cura. Le vetrate a tutta altezza definiscono gli ambienti affacciati sul rigoglioso giardino spontaneo. Una natura protagonista che rigenera e calma.

A secret retreat in the greenness of the Tuscan Apennines. The spaces are large and fluid, furnished with a few carefully selected items. Full-height windows define the rooms overlooking the lush, native garden. Nature takes the lead, regenerating and calming.







LAMPADA ALBA DESIGN I.VISCARDI

LAMP ALBA DESIGN I.VISCARDI



La luce naturale inonda il grande living arredato con il divano Olivier ed è completata da quella della lampada da tavolo Alba; una luce morbida e delicata che emerge discretamente dalle sue forme morbide.

Natural light floods the large living room furnished with the Olivier sofa and is complemented by that of the Alba table lamp; a soft, gentle light that discreetly emerges from its soft shapes.



La luce giusta può valorizzare anche una semplice zona di passaggio. La lampada da terra Arno assolve perfettamente a questo compito: è un oggetto raffinato che esprime la sua preziosità nei dettagli e nella sapiente manifattura.

The right light can enhance even a simple passage area. The Arno floor lamp fulfils this task perfectly: it is a refined object that expresses its preciousness in the details and skilful workmanship.

LAMPADA DA TERRA ARNO DESIGN M.NUNZIATI, FINITURA BRUNITO OPACO T013, PELLE 189

FLOOR LAMP ARNO DESIGN M.NUNZIATI, MATT BURNISHED FINISH T013, LEATHER 189







Atmosfera esotica nella camera matrimoniale arredata con il letto, la panca e i comodini della serie Gaudí. Sui comodini la lampada Alba nella versione più piccola, che ben si addice alle atmosfere notturne.

Exotic atmosphere in the master bedroom furnished with the bed, bench and bedside tables from the Gaudí series. On the bedside tables the Alba lamp in the smaller version, which is well suited to night-time atmospheres.

LAMPADA ALBA DESIGN I.VISCARDI

LAMP ALBA DESIGN I.VISCARDI







L'area pranzo è essenziale e raffinata.  
Al tavolo Gaudí sono affiancate le poltroncine a "guscio" Tekton: la seduta è imbottita e confortevole, le gambe in massello riprendono la stessa finitura del tavolo.

The dining area is essential and refined.  
The Gaudí table is flanked by the Tekton 'shell' armchairs: the seat is upholstered and comfortable, the solid wood legs have the same finish as the table.

SEDIA IMBOTTITA TEKTON DESIGN M.NUNZIATI, STRUTTURA ROVERE CAFFÈ N081, SEDUTA A GUSCIO GREG 962

PADDED CHAIR TEKTON DESIGNED BY M.NUNZIATI, STRUCTURE COFFEE-BROWN OAK N081, SEAT GREG 962





LEGNO - WOOD



**N081**  
ROVERE TINTO CAFFÈ  
COFFEE-BROWN-STAINED  
OAK

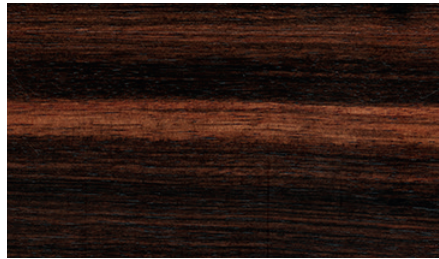

**N089**  
EBANO OPACO  
MATT EBONY



**N074**  
FRASSINO NATURALE  
NATURAL ASHWOOD



**N076**  
FRASSINO TINTO CAFFÈ  
COFFEE-BROWN  
ASHWOOD

FINITURE TERMOSTRUTTURATE - HEAT - STRUCTURED FINISHES



**N051**  
EPOQUE  
BIANCO WHITE



**N052**  
EPOQUE  
GREY

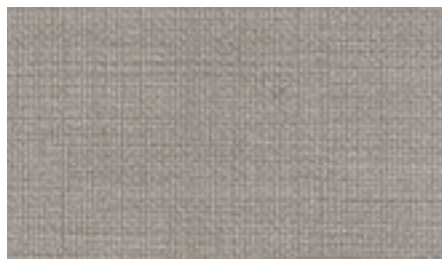

**N012**  
STYLE  
SABBIA SAND

FINITURE METALLI - METAL FINISHES

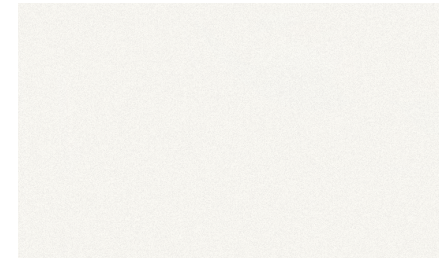

**T011 (011)**  
BIANCO OPACO  
MATT WHITE

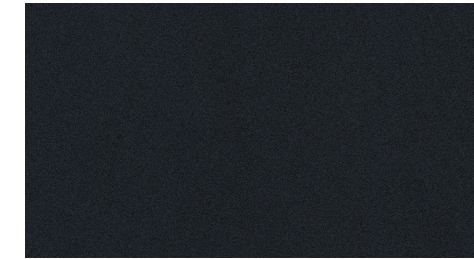

**T012 (010)**  
NERO OPACO  
MATT BLACK



**T010**  
ANODIC BRONZE



**T013 (006)**  
BRUNITO OPACO  
MATT BURNISHED

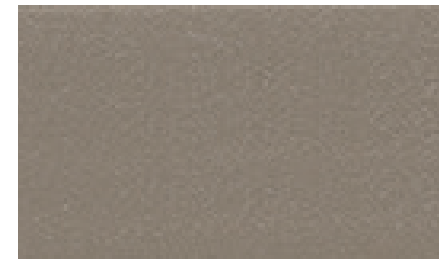

**012 (0069)**  
GRIS SABLÉ

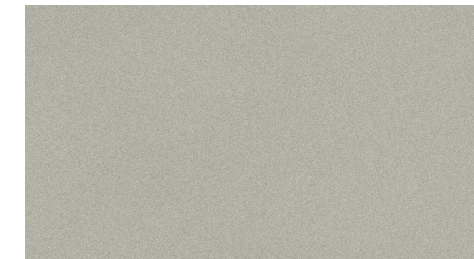

**T019**  
GREIGE OPACO  
MATT GREIGE



**T032**  
OXIDE



**T033**  
SILVER OXIDE

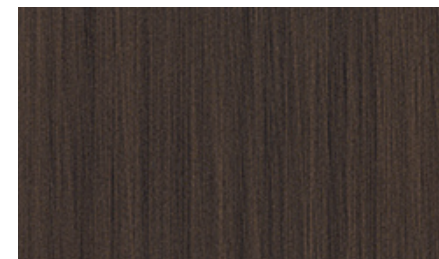

**T029**  
DESERT ROCK



MARMO - MARBLE

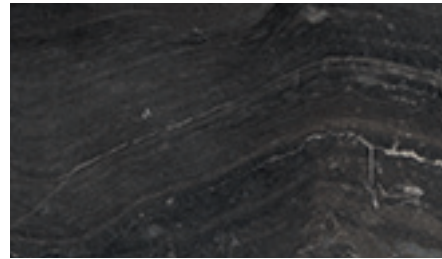

**N070**  
ARABESCO  
ARABESCO

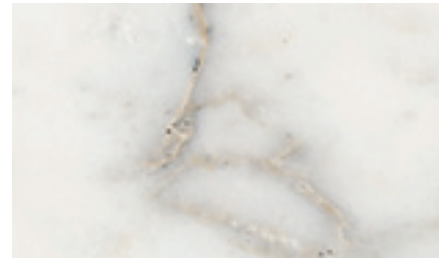

**N060**  
BIANCO DI CARRARA  
LUCIDO  
POLISHED CARRARA  
WHITE

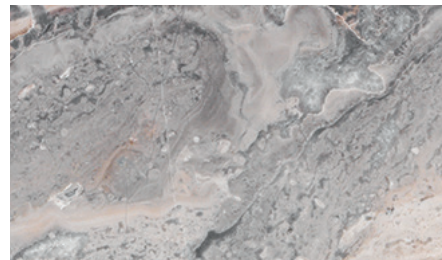

**N063**  
OROBICO GRIGIO  
SPAZZOLATO OPACO  
MATT BRUSHED OROBI-  
CO GREY

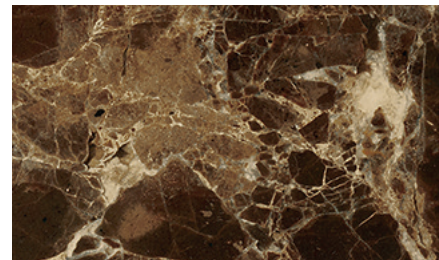

**N064**  
EMPERADOR LUCIDO  
POLISHED EMPERADOR



**N068**  
SILK GEORGETTE LUCIDO  
POLISHED SILK GEOR-  
GETTE

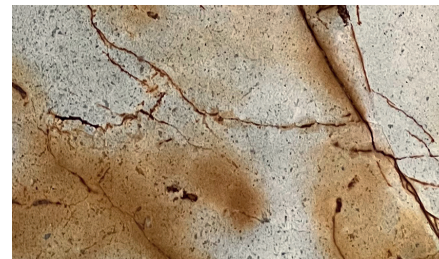

**N057**  
IMPERO ROMANO  
LUCIDO  
POLISHED IMPERO  
ROMANO



**N067**  
CALACATTA ORO  
LUCIDO  
POLISHED CALACATTA  
GOLD

FINITURE VETRO - GLASS FINISHES

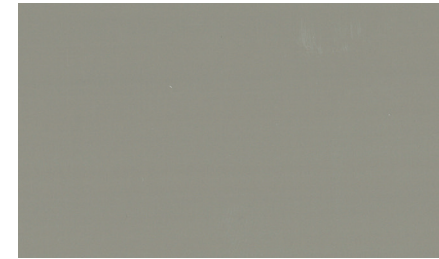

**N038 (0038)**  
VETRO BRONZATO  
BRONZE GLASS



**N039 (0039)**  
VETRO FUMÉ  
SMOKED GLASS

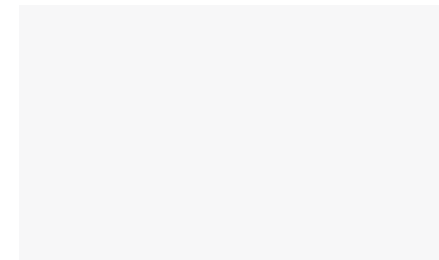

**N040 (0040)**  
VETRO TRASPARENTE  
CLEAR GLASS



**N043**  
SPECCHIO NATURALE  
NATURAL MIRROR



**N033**  
SPECCHIO FUMÉ  
SMOKED MIRROR



**N032**  
SPECCHIO BRONZATO  
BRONZE MIRROR



**003N**  
VETRO NICKEL NERO  
BLACK NICKEL GLASS



**003B**  
VETRO BRUNITO OPACO  
MATT BURNISHED GLASS



COLLEZIONE NATEVO · NATEVO COLLECTION	2	
ALBA	LAMPADE DA TAVOLO · TABLE LAMPS	4
ARNO	SEDIA · ARMCHAIR	6
ARNO	LAMPADE DA TAVOLO E DA TERRA · TABLE AND FLOOR LAMPS	8
ASHAA	LAMPADA DA TERRA · FLOOR LAMP	10
BABELE	LIBRERIA GIREVOLE · SWIVEL BOOKCASE	12
BALLOON	TAVOLO · TABLE	14
BRISCOLA	SEDIA · CHAIR	16
CCLIGHT	LIBRERIA · BOOKCASE	18
CHIARO DI LUNA	COMODINO E LAMPADA · BEDSIDE TABLE AND LAMP	20
CONTINUUM	SCRITTOIO · SCRITTOIO CON SPECCHIO · DESK · WRITING DESK WITH MIRROR	22
FILO ROSSO	LAMPADE DA TAVOLO · TABLE LAMPS	24
KARA	MOBILE MAKE UP · MAKE-UP UNIT	26
PEAK	SPECCHIO · CONSOLLE · MIRROR · CONSOLE	28
RUGIADA	LAMPADE DA TAVOLO E DA TERRA · TABLE AND FLOOR LAMPS	30
SATURNO	SPECCHIO · MIRROR	32
SKI	APPENDIABITI · CLOTHES STAND	34
SOFTWING	LAMPADE DA TAVOLO E DA TERRA · TABLE AND FLOOR LAMPS	36
STAAR	LAMPADA DA TERRA · FLOOR LAMP	38
TEKTON	COLLEZIONE DI SEDUTE · SEATING COLLECTION	40
PROJECTS		42
MATERIALI MATERIALS		92



NATEVO è un marchio di Flou SpA  
via Cadorna, 12 · Meda (MB) · Italia  
t +39 0362 3731  
info@natevo.com  
www.natevo.com