

2024

Collection

flou

Yuna

The new Yuna bed sums up, through the generous sign of the headboard, a domestic object that embraces and involves the 'sleeping ritual'. Generosity, form, function, elegance, succinctly express the emotional path of the design thought.

Carlo Colombo

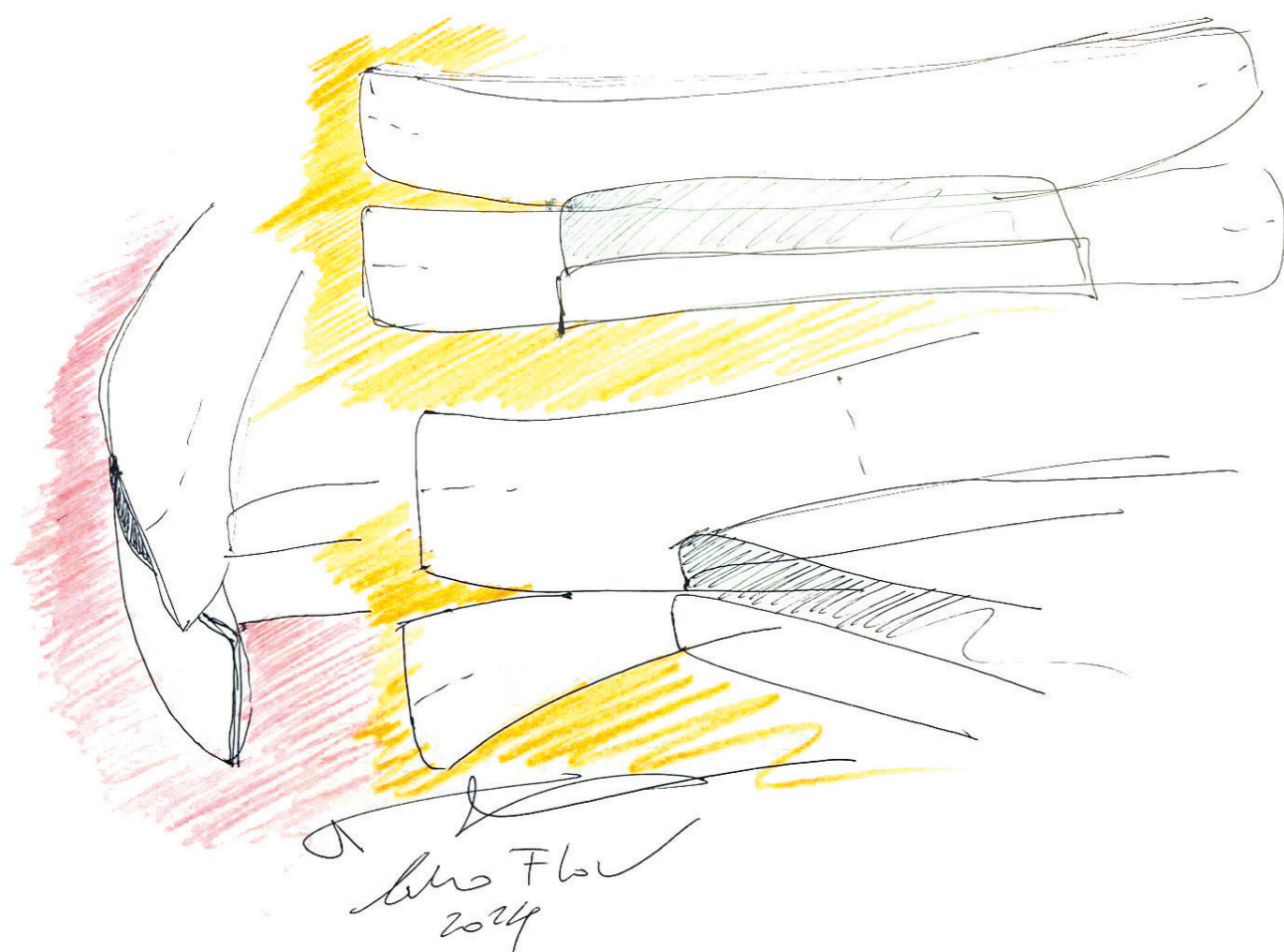

Yuna is part of Flou's range of important and decidedly contemporary textile beds, designed to become the focal point of elegant and refined bedrooms. The generously padded headboard is composed of two overlapping horizontal panels that extend to the sides of the sommier with slightly different curvature radii; a stylistic detail that lightens the overall vision and at the same time accentuates the sensation of welcome and comfort that the design wants to convey.

A further strong point of Yuna is the richness of the materials selected: the back of the headboard is in leather, while the front and the sommier can be in either leather or fabric, offering numerous design combinations with a sure decorative effect and making the bed perfect also for placement in the centre of the room.



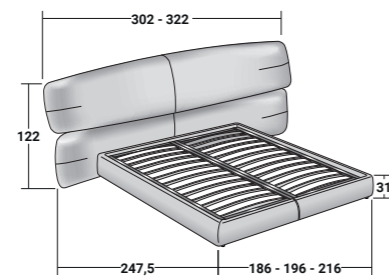
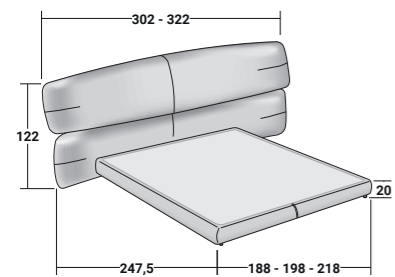

YUNA - double bed
design Carlo Colombo

Double bed available with Leonardo H16 base, H25 base with adjustable slats, storage base and Motion 4 base. The base and the front part of the headboard are upholstered in fabric or leather with completely removable covers, while the back cover is not removable and can only be made in leather or Greene coated fabric. The two headboard panels are however removable to facilitate the removal of the front cover.



AtelierM

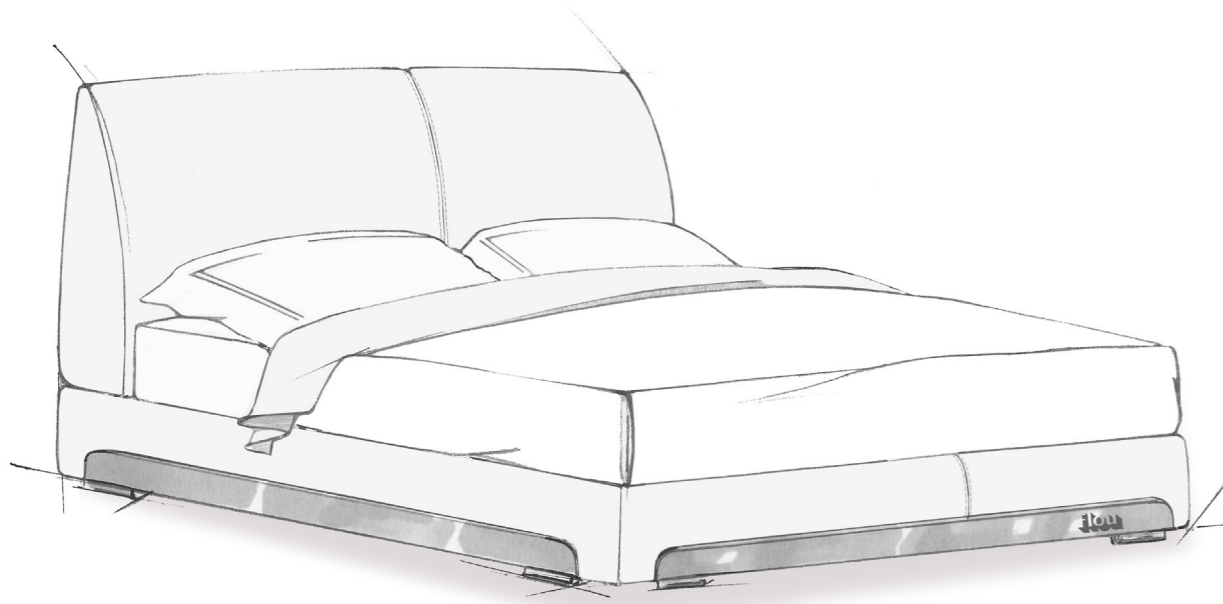

AtelierM is a double bed that fully reflects Flou's values of tailoring and manufacturing excellence, starting with the upholstered textile headboard whose soft linearity is interrupted by a vertical cut with a pleated effect.

But the detail that characterises it is undoubtedly the base, with its minimalist shape set in a folded sheet metal profile that leaves the corners visible; a choice of materials that allows multiple combinations between the textile covering and the finishes proposed for the metal.

And like any self-respecting sartorial suit, AtelierM also has its own label that identifies and distinguishes it: the laser-etched Flou logo on the metal profile, highlighted in contrasting colours.

AtelierM was born from the desire to combine my great passions for Interior Design and Fashion. A bed constructed like a dress, thinking about games of shapes and overlapping and mixing materials, finishes and colours.

Gino Moschetti



AtelierM - double bed
design Gino Moschetti

Double bed available with Leonardo base, H25 base with adjustable slats, storage base with adjustable slats, Motion 4 base. Metal base/footboard in the following finishes: anodic bronze T010, matt burnished T013, matt white T011, matt black T012, matt greige T019, oxide T032, silver oxide T033, desert rock T029.

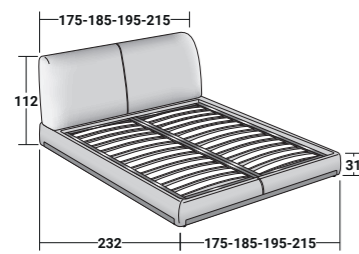



Fiocco

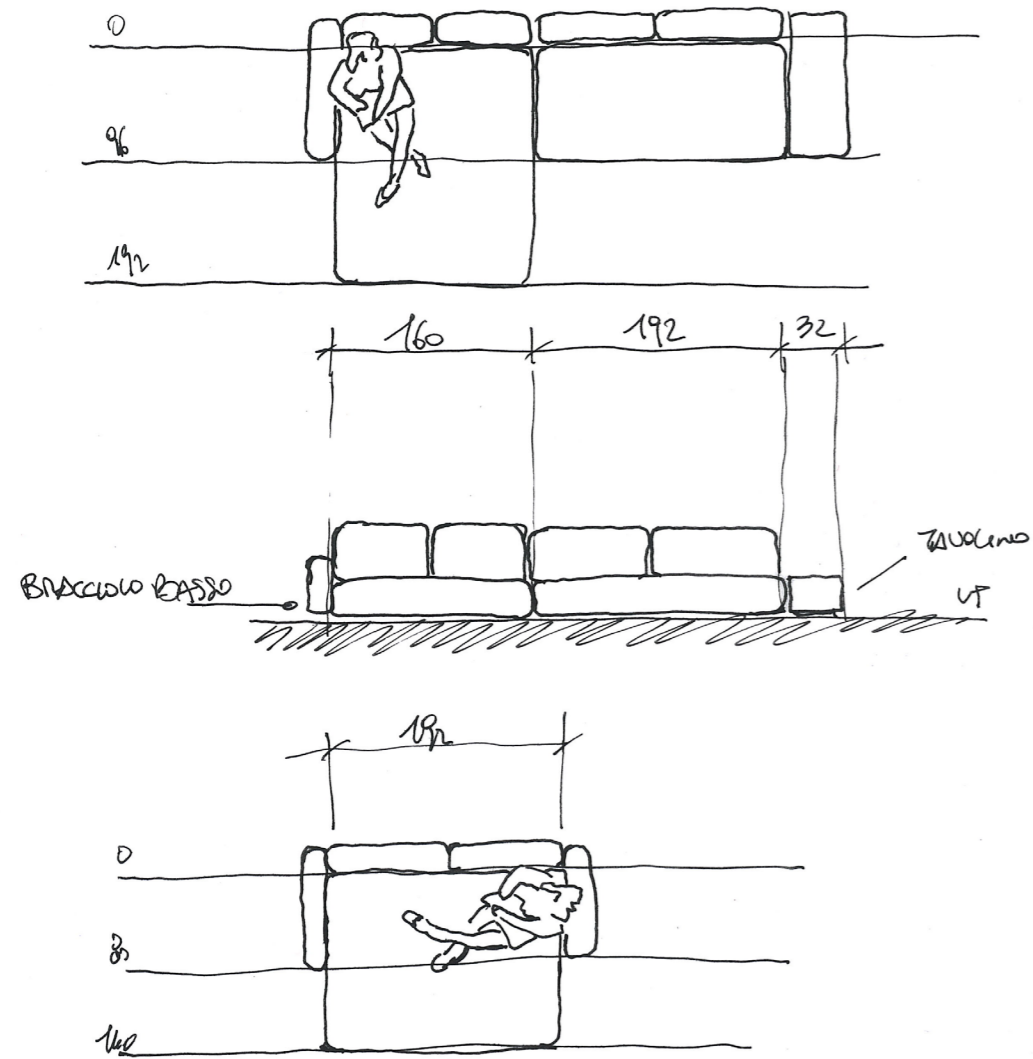

Softer and more enveloping than ever, Fiocco's modules 'expand' to become true islands of relaxation and well-being.

Pinuccio Borgonovo



FIOCCO - modular sofa
design Pinuccio Borghonovo

The modular system Fiocco is enriched with seven seat modules of particularly large dimensions, two armrest modules and a backrest module. The new elements allow even larger, softer and more articulated compositions to furnish the spaces of relaxation, conviviality and hospitality in an unconventional and modern way.

The possibility of inserting the new Foglio tables between the modules creates support points and amplifies the versatility and usability of the system.

The new Fiocco elements are also available in both indoor and outdoor versions.



BACKREST/ARMREST

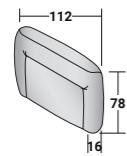

ARMRESTS

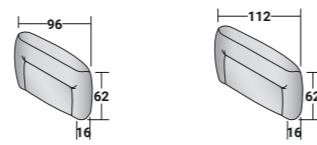

SEAT MODULES

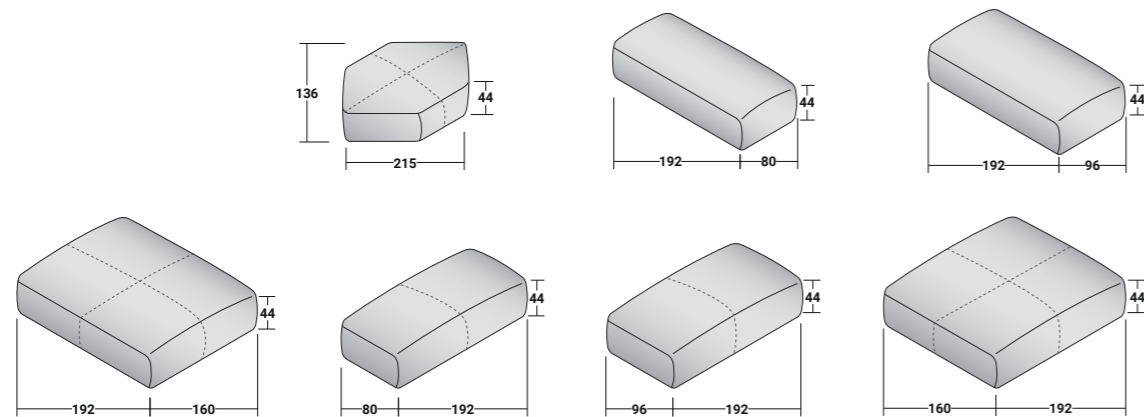



The new Fiocco sofa modules, which are irregular and large in size, further enhance the versatility of the system.

Foglio

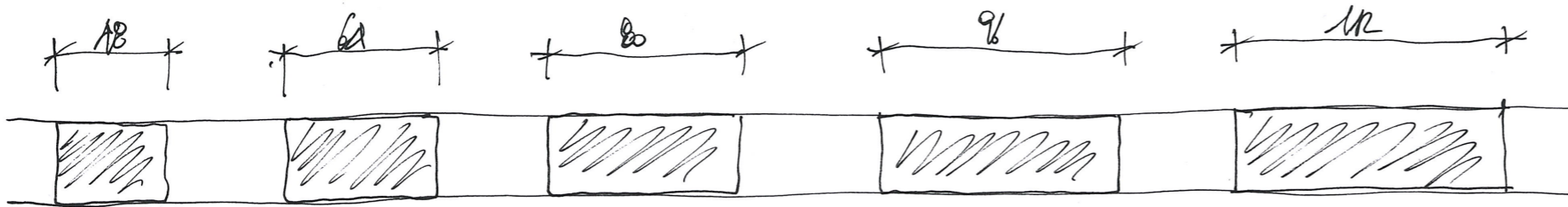

It is thanks to its simplicity of design that the Foglio system allows for the creation of new and original solutions consistent with its original idea.

Pinuccio Borgonovo

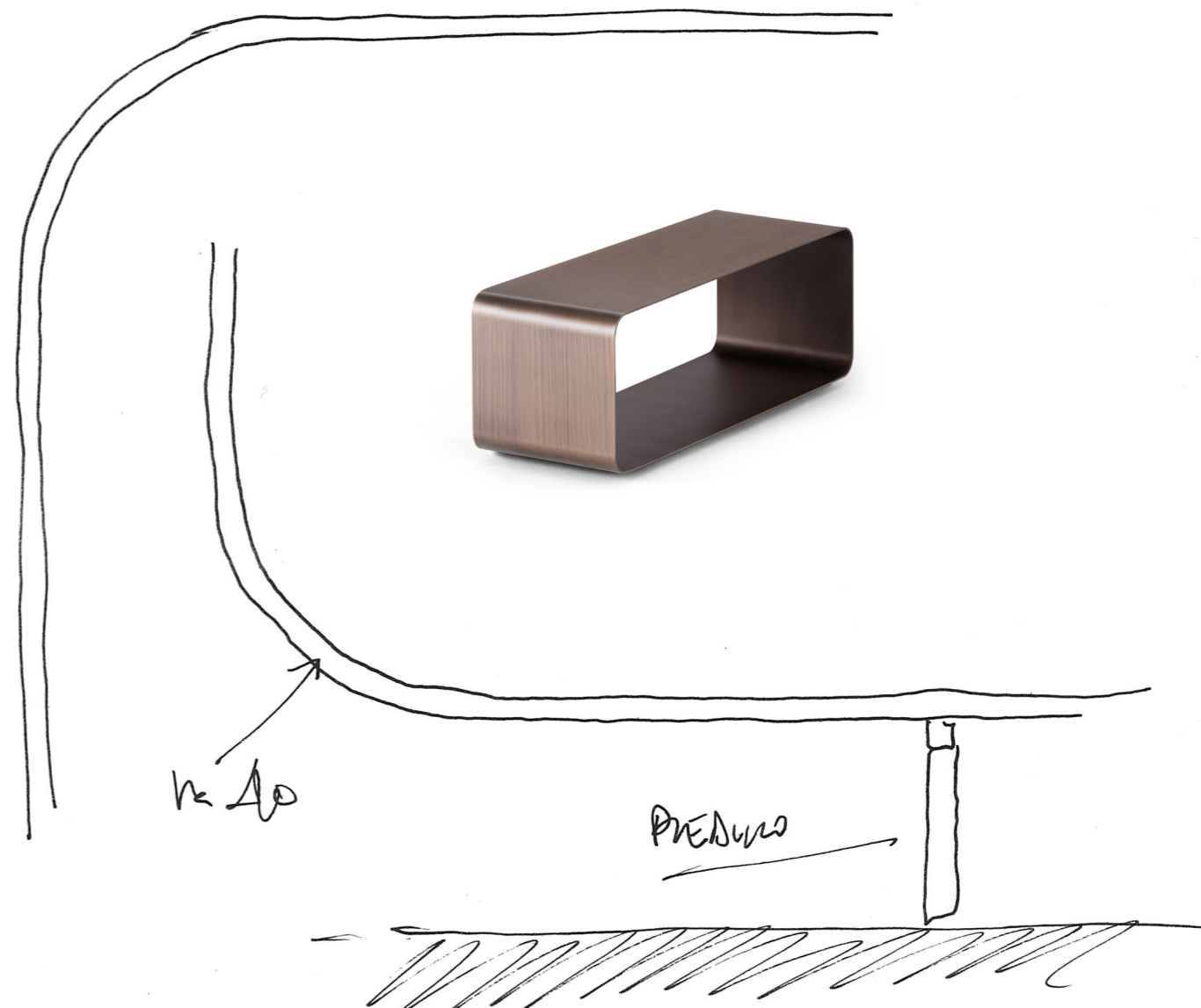
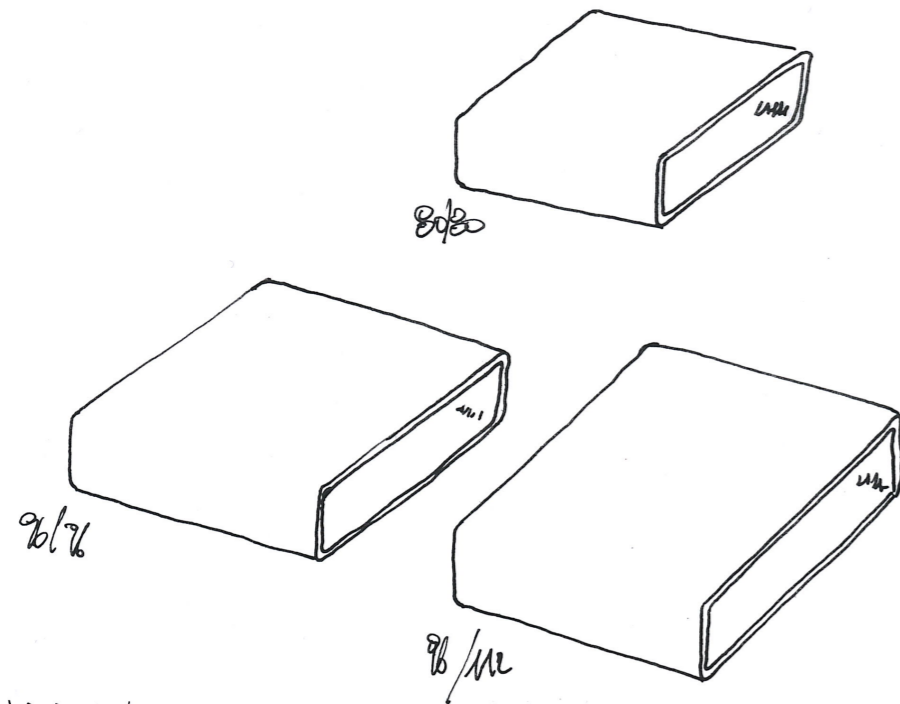

An evolution of the complementary system of the same name, the Foglio coffee tables are made of a simple curved metal sheet with rounded edges and a hollow internal space that can be used as a table top. The dimensions are specifically designed not only to create compositions for the centre of the living room but also to be inserted between the seating elements of the modular Fiocco sofa, breaking up the continuity of the fabric and creating movement even in larger compositions.

Available finishes: anodic bronze T010, matt burnished T013, matt white T011, matt black T012, matt greige T019, oxide T032, silver oxide T033 and desert rock T029.

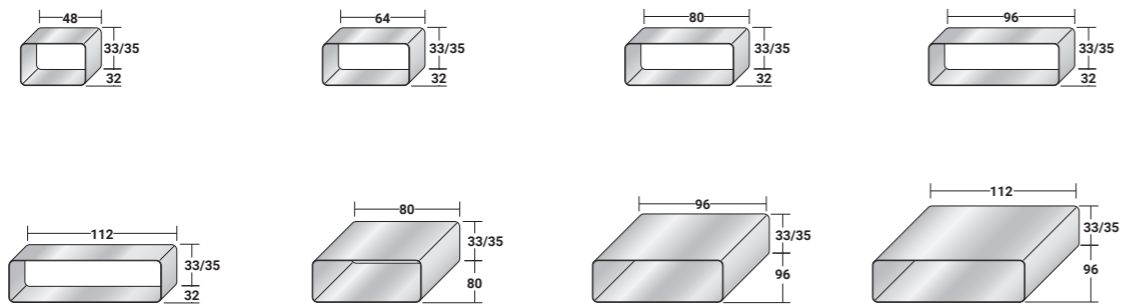
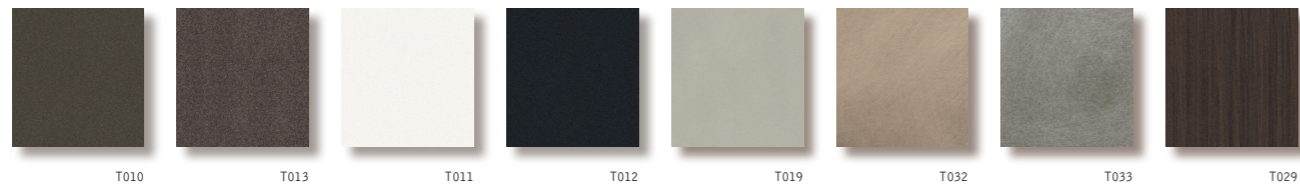

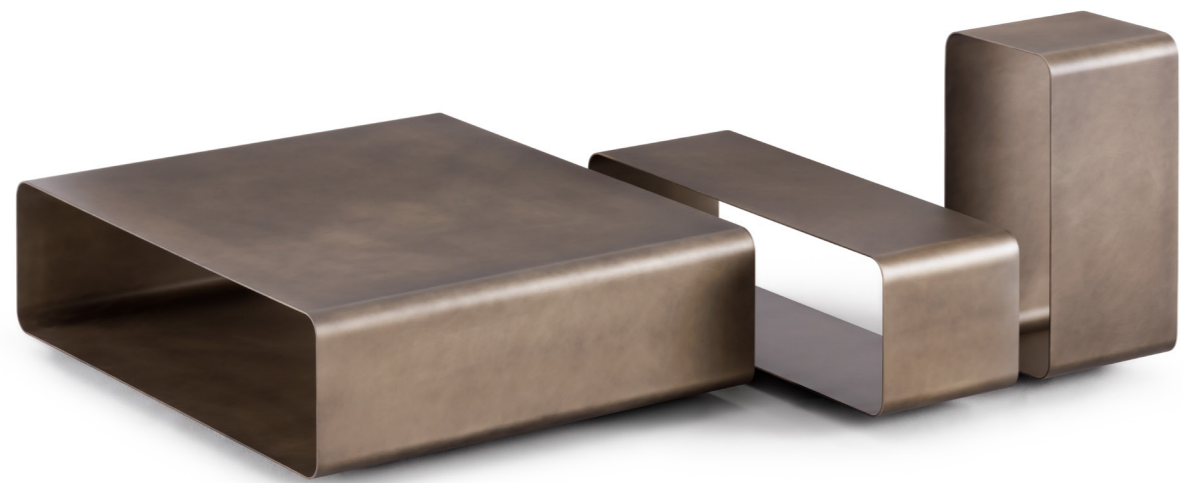

Foglio coffee tables in Oxide and Desert Rock versions:
two of the available finishes for the metal surface.

The Foglio shelves in curved metal are offered in two new lengths 91 cm and 121 cm. Their dimensions are smaller both in length and depth than those already in the catalogue, making them easy to use even in an entrance hall as a shelf.

Finishes available: white T011, anodic bronze T010, matt burnished T013, matt greige T019, black T012, oxide T032, silver oxide T033 and desert rock T029.

The front of the shelves can be smoked or bronzed mirror or in the same finish as the metal.

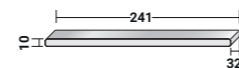
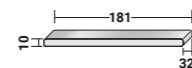
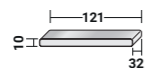
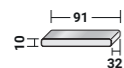

Olivier

Upgrade of the highly successful Olivier sectional:
 the 280 cm long two-seater frame module is joined by
 one with the same size but with three-seater cushions.
 The element can be inserted into corner combinations or,
 with the addition of both armrests, become a classic
 three-seater in line, sober and sophisticated.

Sophisticated in its sobriety, Olivier is a sofa with spacious, ample and comfortable seating.
 An exclusive and elegant line for contemporary environments of refined taste.

Emanuela Garbin - Mario Dell'Orto

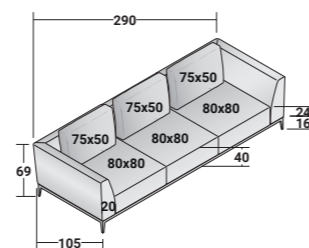

Pierre

Seats and accessories with an informal and relaxed mood, in continuity with our research work on the soft shapes of nature.

Studio Contromano

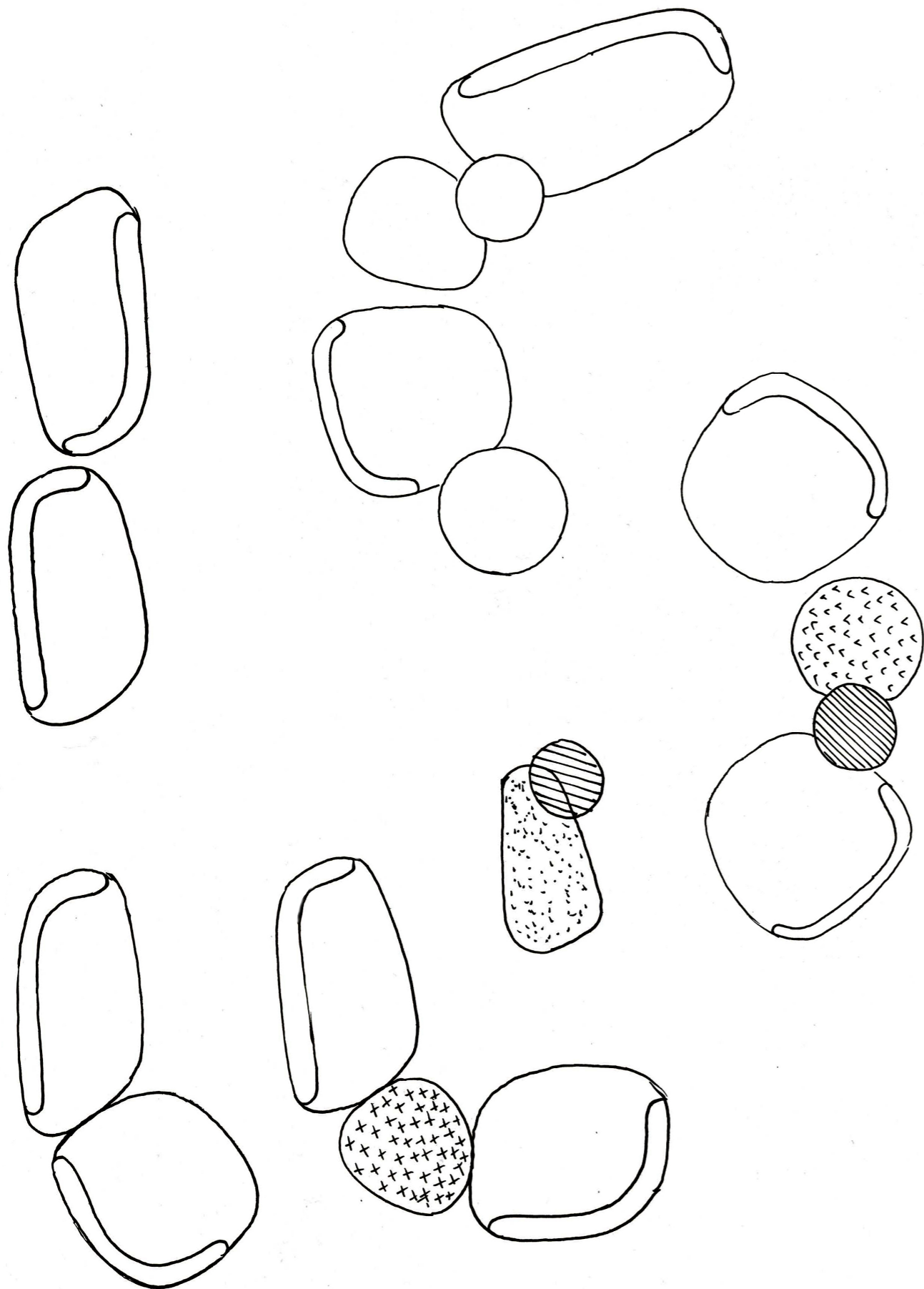

The poufs, small armchairs and sofas in the Pierre series amplify their decorative value thanks to the possibility of a "multicolour" upholstery, freely combining each proposal in the textile catalogue.

For the poufs, the upholstery is two-coloured: one for the side band and one for the seat.

For the armchairs and sofas, the upholstery can combine as many as three different colours and textures: one for the side band, one for the seat and one for the back.

All elements are available in both indoor and outdoor versions.

Three new sizes also for the Pierre round tables, for indoor and outdoor use, in all the finishes already in the catalogue.

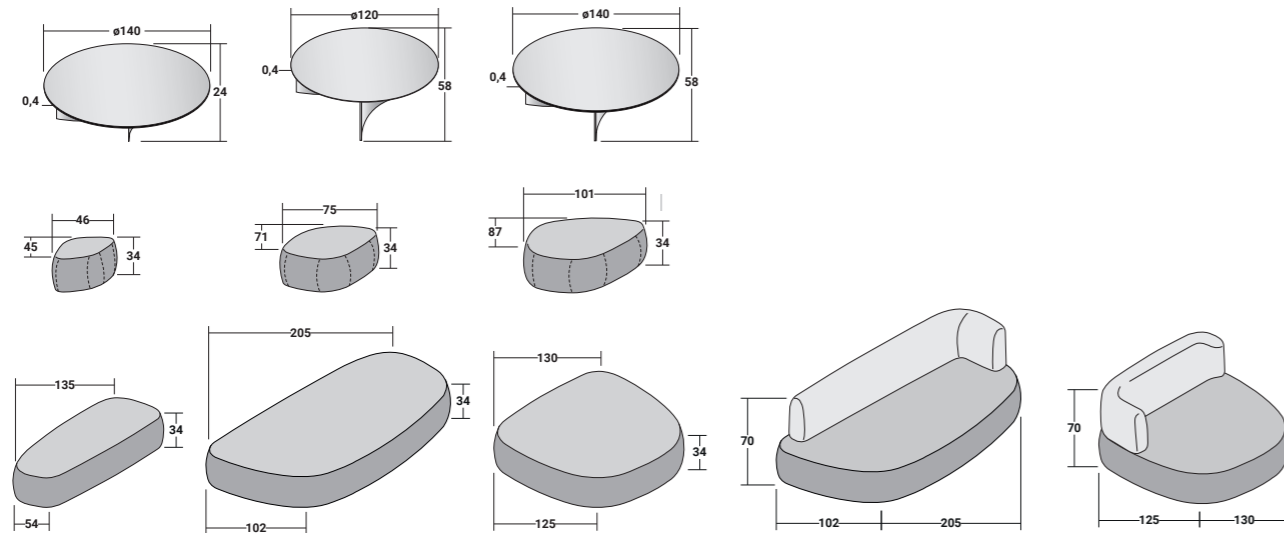

Madame Butterfly

Madame Butterfly has an organic, sinuous line, inspired by the shape of butterfly wings.

From their flight comes the design of the backrest: a single, soft, undivided element designed to offer the warmth of an embrace.

Full and voluptuous volumes for an elegant and timeless aesthetic.

The Touch Studio

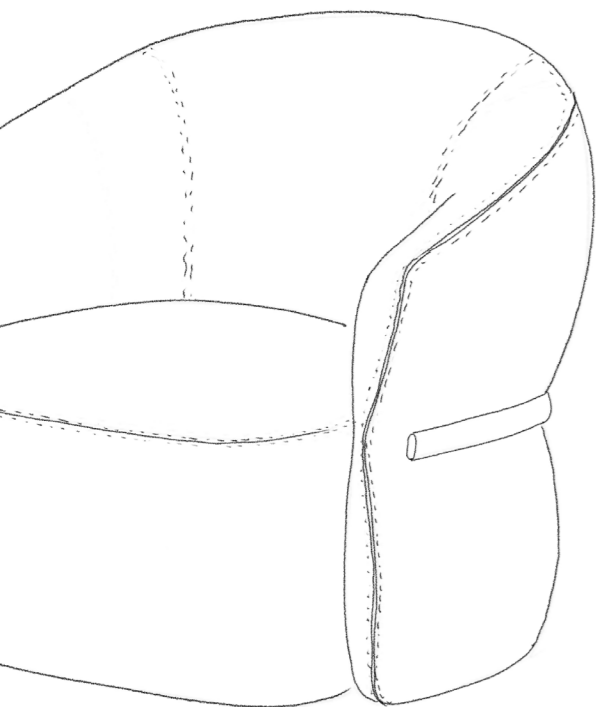

Alongside the traditional version, Madame Butterfly is also offered as a 360° swivel armchair. The structure is supported by an iron plate to which the swivel mechanism is attached.

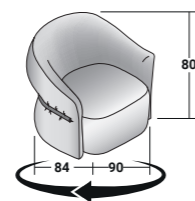

Grace

Light, a dress and a female presence:
Grace.

Daniele Lo Scalzo Moscheri

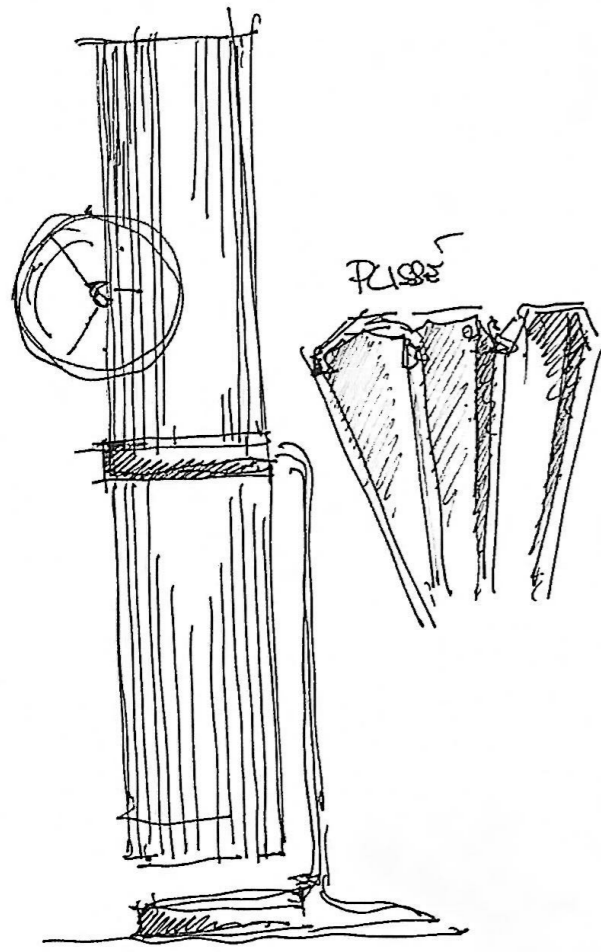

Grace is a lamp that combines design and textile culture, innovation and tradition; a light source that lights up and elegantly expands space without excess. two overlapping cylindrical volumes covered with white pleated fabric lampshades are attached to a painted metal supporting structure; the special linear weave creates a vertical graphic motif that slims the shape and diffuses the light in a discreet, homogeneous and unobtrusive manner.

A lamp with a feminine name that refers to a contemporary romanticism, a linear and clean taste and a timeless style.



GRACE - floor lamp
design Daniele Lo Scalzo Moscheri

Floor lamp with supporting structure in epoxy powder-coated metal (colours: anodic bronze T010, matt burnished T013, matt black T012, matt white T011, matt greige T019).

Lampshades in white pleated fabric (70% viscose, 30% polyamide laminated with PVC backing, 3 mm thick).

Black canvas power cable with on/off or dimmer footswitch.

Light source: two dimmable Globo bulbs with E27 socket.

Colour temperature 3,000K

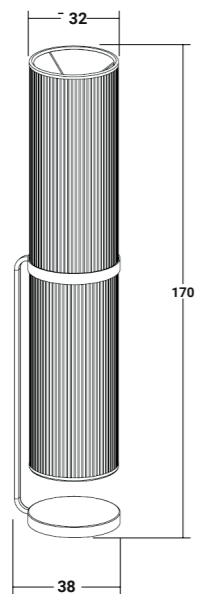



Atollo is a collection of tables with a shaped metal rod structure that rises to embrace and support a round metal or marble table top.

An object with a variety of functions, with a cylindrical container in the centre of the top that can be used as a tray, to store personal objects or to contain green plants and that, thanks to a removable and rechargeable light source, is immediately transformed into a lamp with surprising, soft and suggestive lighting effects.

Atollo is also made with materials and finishes specifically designed to allow its use outdoors.

Atollo

Atollo is an object that combines aesthetics and function, fulfilling many small needs with an original and elegant design. Like an atoll proudly rising above the sea, the light completes it, enhances its shapes and makes them dance, like the soft reflections of the sun in a calm sea.

Ilenia Viscardi

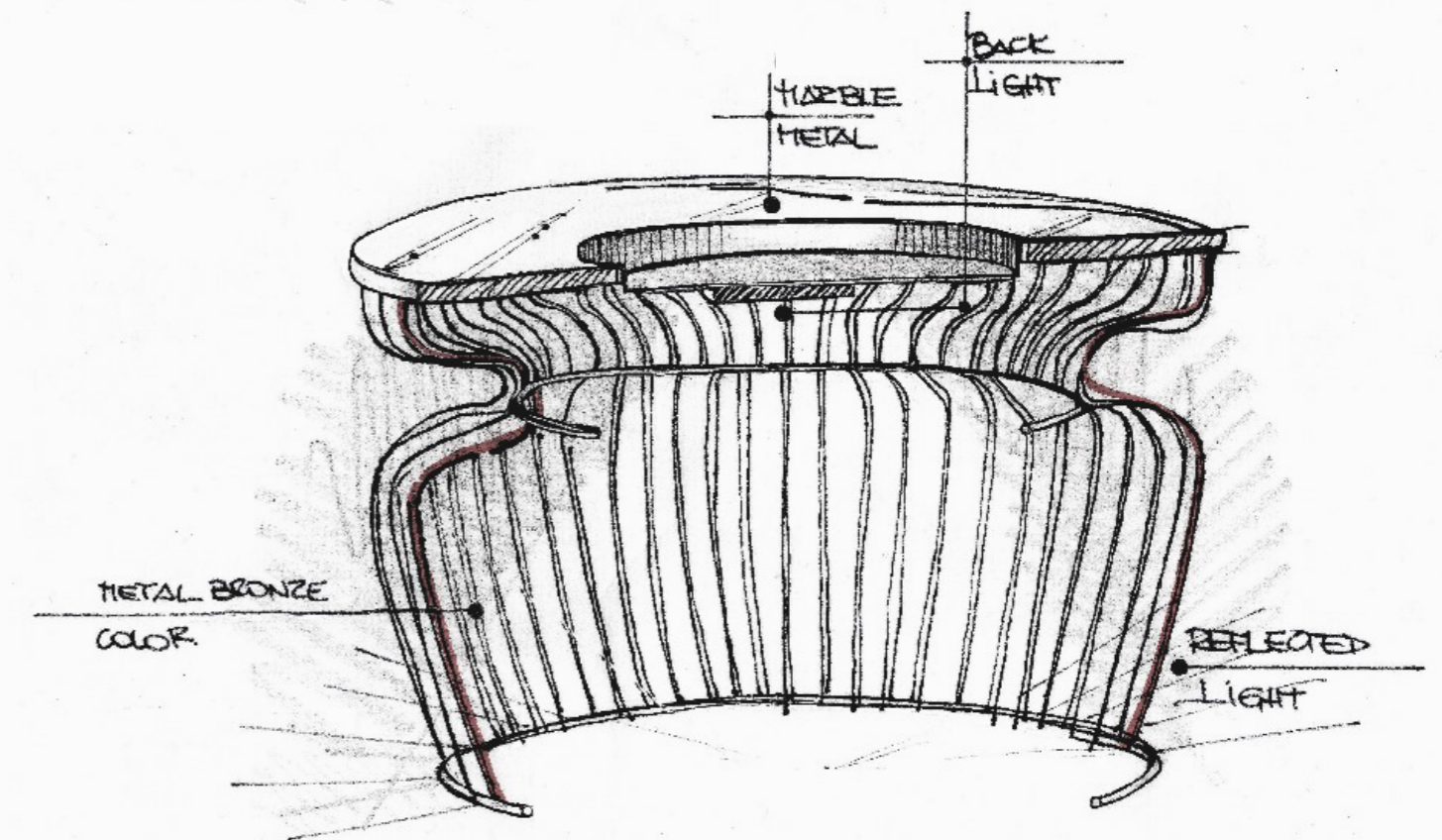



Declined in different materials, sizes and heights,
Atollo becomes a side table or high table, also for furnishing outdoor spaces.

ATOLLO - coffee tables
design Ilenia Viscardi

Small tables with an iron frame (indoor version) or stainless steel frame (outdoor version) painted in different finishes and with marble or metal top.

The metal and marble tops have a central hole prepared to be completed with a metal cover (finish as the structure) or a cylindrical metal container (finish as the structure) which can be used as a holder for objects or as a vase.

The metal top can also be chosen in the same finish as the structure or in a different finish.

All coffee tables are also available with a removable and rechargeable light source with the following characteristics: water resistant (IP68), colour temperature 2,700 K; autonomy at maximum light intensity 3h 30".

INDOOR VERSION

STRUCTURE

matt burnished T013	matt black T012
anodic bronze T010	matt greige T019
matt white T011	

TOP

matt burnished T013	Oxide T032
anodic bronze T010	Silver Oxide T033
matt white T011	Desert Rock T029
matt black T012	
matt greige T019	

Bianco di Carrara N060	Arabesco N070
Emperador N064	Calacatta oro N067
Orobico grigio N063	Impero Romano N057
Silk Georgette N068	

CONTAINER

matt burnished T013	matt black T012
anodic bronze T010	matt greige T019
matt white T011	

TOP COVER

matt burnished T013	matt black T012
anodic bronze T010	greige opaco T019
matt white T011	

OUTDOOR VERSION

STRUCTURE

matt burnished T013	matt black T012
anodic bronze T010	matt greige T019
matt white T011	

TOP

matt burnished T013	matt black T012
anodic bronze T010	matt greige T019
matt white T011	

Bianco di Carrara N060	Impero Romano N057
Calacatta oro N067	

CONTAINER

matt burnished T013	matt black T012
anodic bronze T010	matt greige T019
matt white T011	

TOP COVER

matt burnished T013	matt black T012
anodic bronze T010	matt greige T019
matt white T011	

COFFEE TABLE with metal/marble top - metal cover

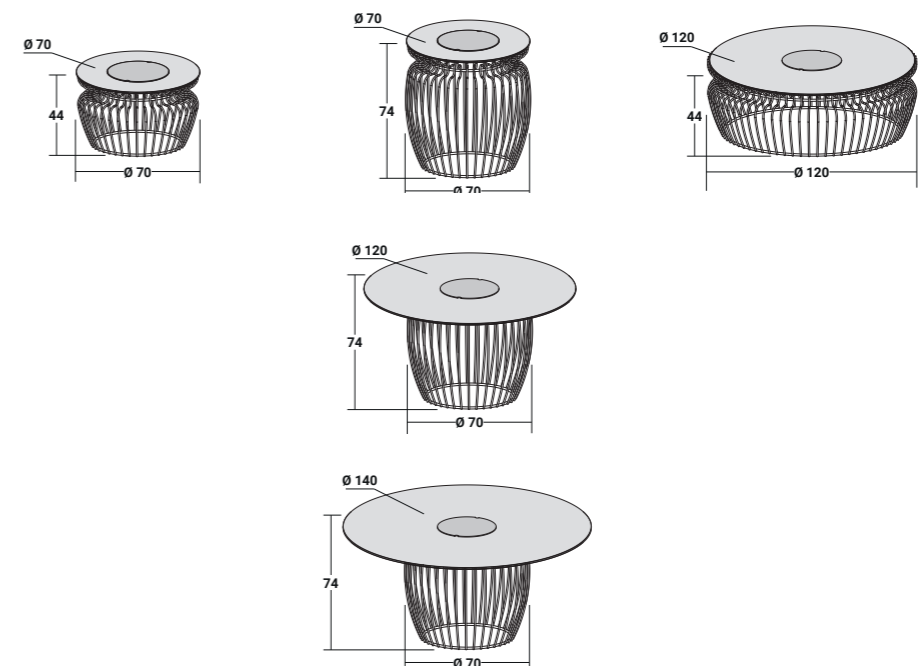

COFFEE TABLE with metal/marble top - metal container

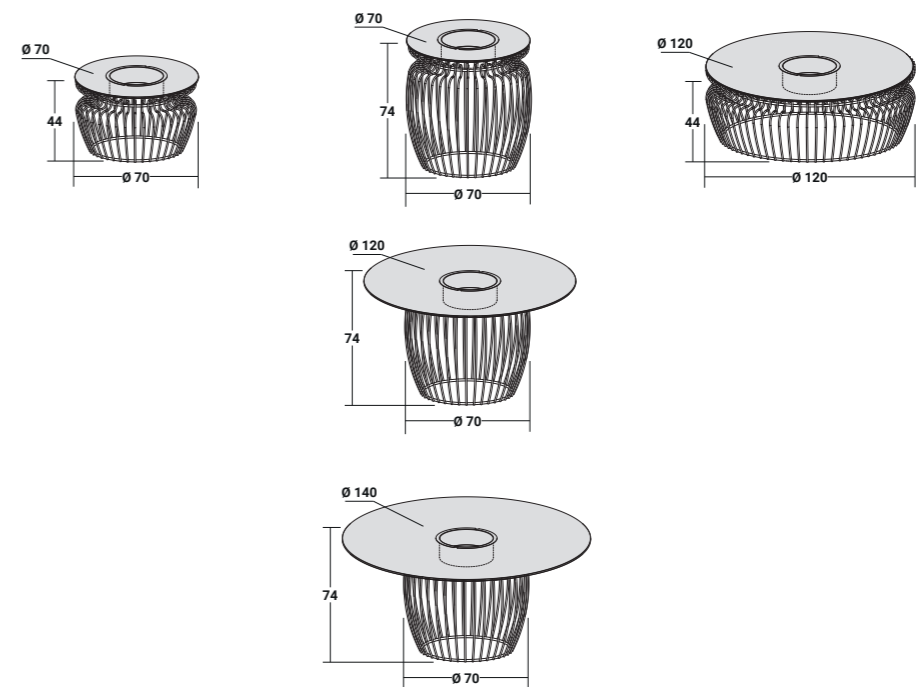

Flou SpA
via Luigi Cadorna, 12
20821 Meda MB
Tel. 0362 3731

info@flou.it
www.flou.it

